

Operation Manual

DTF-1201E

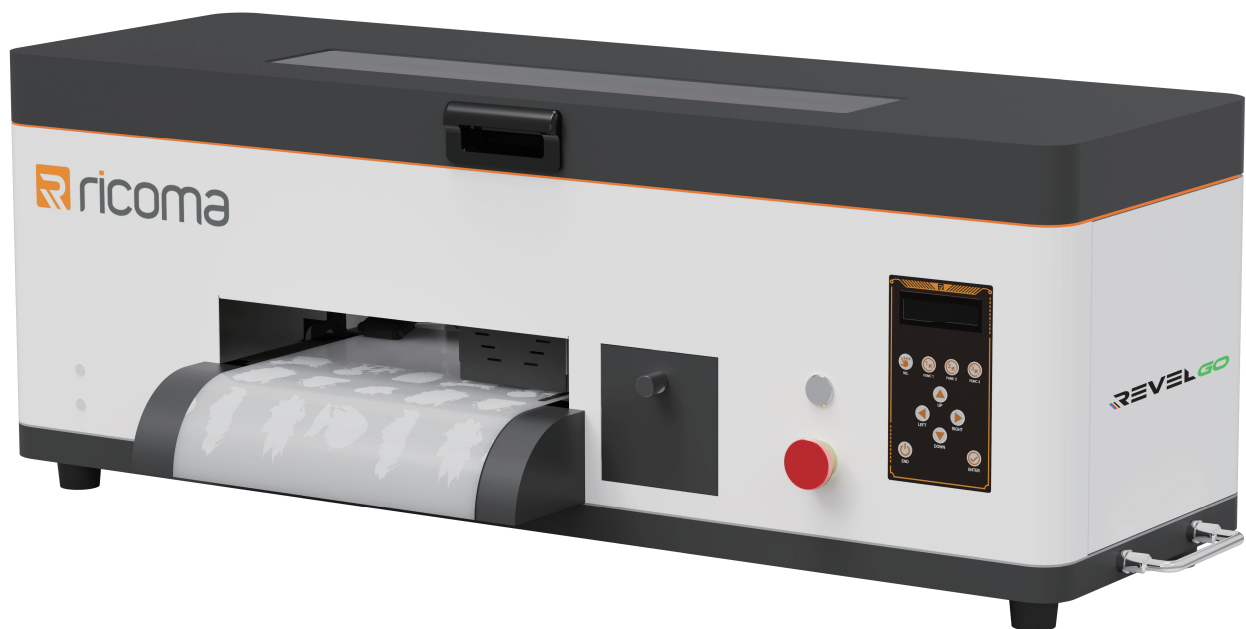

- To ensure correct and safe use of this product based on a full understanding of its performance, please read this manual thoroughly and keep it for future reference.
- Unauthorized reproduction, either in whole or in part, of this manual is strictly prohibited. The company will pursue legal action against any such infringement.
- The contents of this manual and the specifications of this product are subject to change without prior notice.
- We have made every effort to ensure the accuracy of this operation manual and to test the product. If you find any printing errors or mistakes, please inform us. Your feedback would be greatly appreciated.

All rights reserved. Unauthorized copying will be prosecuted.

2025.11.5

Version Revel Go DTF-1201E_1.0

Contents

Chapter 1 Printer Safety Instructions	01
1.1 Important Safety Instructions	01
1.2 Precautions When Using the Printer.....	01
1.3 Precautions for Ink Cartridge Usage	01
1.4 Printer Installation Requirements.....	02
1.5 Warnings, Cautions, and Notes.....	03
Chapter 2 Structural Diagrams	04
2.1 Function Introduction	04
2.2 Overall Appearance Structure Diagram.....	04
2.3 Carriage Structure Diagram.....	05
2.4 Left-Side Interior View of the DTF-1201E Printer	05
2.5 Right-Side Interior View of the DTF-1201E Printer	05
Chapter 3 Printer Basic Parameters	06
3.1 Basic Parameters.....	06
Chapter 4 Hardware Installation	07
4.1 Introduction to the Printing System.....	07
4.2 Printer Control Board Interface Definition.....	07
4.3 Nozzle Configuration.....	08
4.4 Motherboard Interface.....	08
4.5 Motherboard Wiring and Pin Definitions.....	09
4.6 Printer Board Installation and Wiring Diagram	10
Chapter 5 Software	10
5.1 Software Installation.....	10
Chapter 6 Nozzle Installation	12
6.1 Carriage Board Printhead Arrangement.....	12
6.2 Printhead Data Cable Connection Methods	13
Chapter 7 Computer Connection Settings For Printing Software	14
7.1 Set Computer IP Network.....	14
7.2 General Software Settings	14
7.3 Control Panel Description.....	17
Chapter 8: Procedures for Printing Calibration Adjustment	18

8.1 Introduction for Nozzle Detection Function	18
8.2 Stepping Calibration Function	19
8.3 Calibration of the Horizontal Spacing of Nozzles.....	20
8.4 Calibration of Longitudinal Spacing of Nozzles.....	21
8.5 Bidirectional Calibration	22
8.6 Color Calibration	23
Chapter 9: Installation and Usage of RIIN Software.....	25
9.1 RIIN Installation	25
9.2 Introduction and Usage Instructions of RIIN Interface.....	27
Chapter 10 Maintenance Guidelines	28

Chapter 1 Printer Safety Instructions

Please read the following instructions before using your DTF-1201E printer series product, and observe all warnings and instructions marked on the printer.

1.1 Important Safety Instructions

- Do not block any openings on the printer's enclosure.
- Do not insert any objects into the slots of the printer; take care to avoid spilling liquids into the printer.
- Only use the power type specified on the printer's label. Depending on the country or region, either 110V or 220V AC power may be required.
- Connect all equipment to a properly grounded outlet. Avoid using outlets on the same circuit as devices that regularly switch on and off, such as copiers or air conditioning systems.
- Avoid using outlets controlled by wall switches or automatic timers.
- Keep your computer system away from potential sources of electromagnetic interference, such as speakers or cordless telephone bases.
- Do not use damaged or worn power cords.
- If using an additional power cord, ensure the total amperage of all devices connected to it does not exceed the cord's rated amperage. Also, ensure the total amperage of all devices plugged into the wall outlet does not exceed the outlet's rated amperage.
- Do not attempt to repair the printer yourself.
- Disconnect the power and contact qualified service personnel if any of the following occur:
 - a. If the power cord or plug is damaged;
 - b. If liquid is spilled into the printer;
 - c. If the printer is dropped or the enclosure is damaged;
 - d. If the printer does not operate normally or shows a significant change in performance.

1.2 Precautions When Using the Printer

- Do not move the printhead by hand, as this may damage the printer.
- Always use the power switch to turn off the printer. When the switch is pressed, the power will be cut off. Do not unplug the printer's power cord or data cable until the power has been fully disconnected.
- Before moving the printer, ensure the printhead is in its home position and secure it.

1.3 Precautions for Ink Cartridge Usage

- Keep ink cartridges out of the reach of children. Prevent children from drinking or coming into contact with the ink.

1.4 Printer Installation Requirements

- Site preparation

The customer is responsible for complying with all installation requirements and maintaining them during the machine's operation. Failure to do so may result in improper machine function.

- Work Area

The Work Area refers to the region adjacent to the DTF-1201E printer (hereinafter referred to as the equipment), as shown in the diagram (Length × Width × Height: 1077 × 586 × 382 mm / 42.4 × 23.1 × 15.0 in).

It is essential to emphasize that users must ensure the safety of personnel operating within this area.

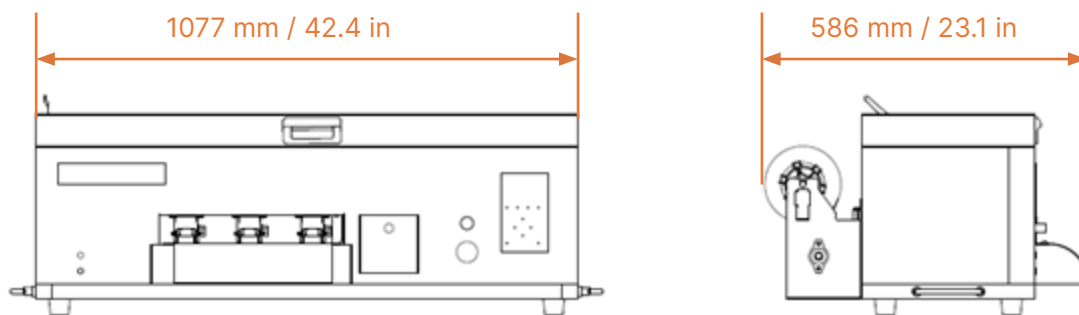

Figure 1: Work Area Diagram Surrounding the DTF-1201E Printer (Units: mm)

- Environmental Requirements

The equipment should be kept away from seaming machines (fabric splicing machines) or other radio frequency sources. The floor should be easy to clean and should not generate dust or static electricity. To assist operators and customers in accurately judging color, neutral gray finishes and pure white light (fluorescent lighting) are recommended for illumination. The equipment should be installed in a clean, dust-free environment with temperature and relative humidity controlled within the following ranges:

1. Altitude: Below 1000 meters
2. Operating Temperature: 15–30°C
3. Relative Humidity: 35%–70%

- Space Clearance Requirements

The equipment requires 2.0 meters of clearance in front, 1.0 meter at the back, and 1.0 meter on each side. Additionally, the clearance area includes a height of 3 meters above the floor. Furthermore, space should be left in front of and behind the machine to allow for loading and unloading media and consumables.

- Safety Requirements

1. Fire Prevention

Inks and solvents must be stored in dedicated flammable-liquid storage cabinets or in separate storage rooms, clearly labeled to comply with professional safety regulations.

Ink storage must strictly adhere to local fire codes governing the use and storage of flammable materials. Carbon dioxide (CO₂) and dry chemical fire extinguishers must be placed in clearly visible and easily accessible locations along all access routes. They should be positioned near the equipment and flammable-liquid storage cabinets (or rooms), or as otherwise required by local fire regulations.

2. Ventilation

Adequate ventilation is essential to prevent hazardous accumulation of volatile vapors. The air in the work area must be replaced approximately 6 to 8 times per hour. Ventilation inlets should be positioned low enough to prevent vapors from accumulating near the floor.

An exhaust system is required to remove solvent vapors released during fabric drying, as solvents in the ink evaporate when passing through the dryer.

Note: Solvent vapors are heavier than air and tend to accumulate near the floor.

Electrical equipment installed near the work area must comply with GB/T standards and relevant national electrical codes for Class I, Division 2 hazardous locations, and must be installed by a qualified, licensed electrical contractor.

Disposal of hazardous waste generated during printer operation must conform to specific storage and handling requirements mandated by relevant authorities.

3. Electrical Requirements (It is strongly recommended to equip the system with a UPS and a voltage stabilizer.)

The DTF-1201E printer uses single-phase power and must be properly grounded. (Voltage between ground wire and neutral wire must not exceed 0.3 V. Grounding resistance must be less than 3 Ω .)

Power supply specifications: Voltage: 220 V AC ($\pm 10\%$)

Frequency: 50 Hz or 60 Hz

Users must have a qualified electrician or licensed contractor install the power outlet. Circuit breaker ratings are as follows:

Power Supply / Voltage	220 V AC	110 V AC
Single-phase	10 A / phase	20 A / phase

Maximum power consumption: less than 0.3 kW;

Average power consumption: approximately 0.25 kW.

Recommended Ups capacity: 2 kVA (used for all power needs except heating)

The main power outlet must be located no more than 2 meters from the equipment's power input terminal.

DTF Printer Power Rating: Approximately 250 W.

It is recommended to use a voltage stabilizer.

Ground Wire Installation: Connect the ground wire to the common grounding metal plate inside the equipment. Then, set a multimeter to the 200 V AC range, place one probe on the ground wire and the other on the neutral line of the AC input.

A reading below 1 V is acceptable.

1.5 Warnings, Cautions, and Notes

- Warning: Must be followed to prevent personal injury.
- Caution: Must be observed to avoid equipment damage.
- Note: Contains important operational information and helpful tips for using the printer.

Chapter 2 Structural Diagrams

2.1 Function Introduction

- 24-hour white ink circulation: Shut down only by pressing the emergency stop button, while the power switch remains powered on to allow for 24-hour continuous white ink circulation.
- The following diagram illustrates the button and interface functions.

Shut down only by pressing the emergency stop button, while the power switch remains powered on to allow for 24-hour continuous white ink circulation.

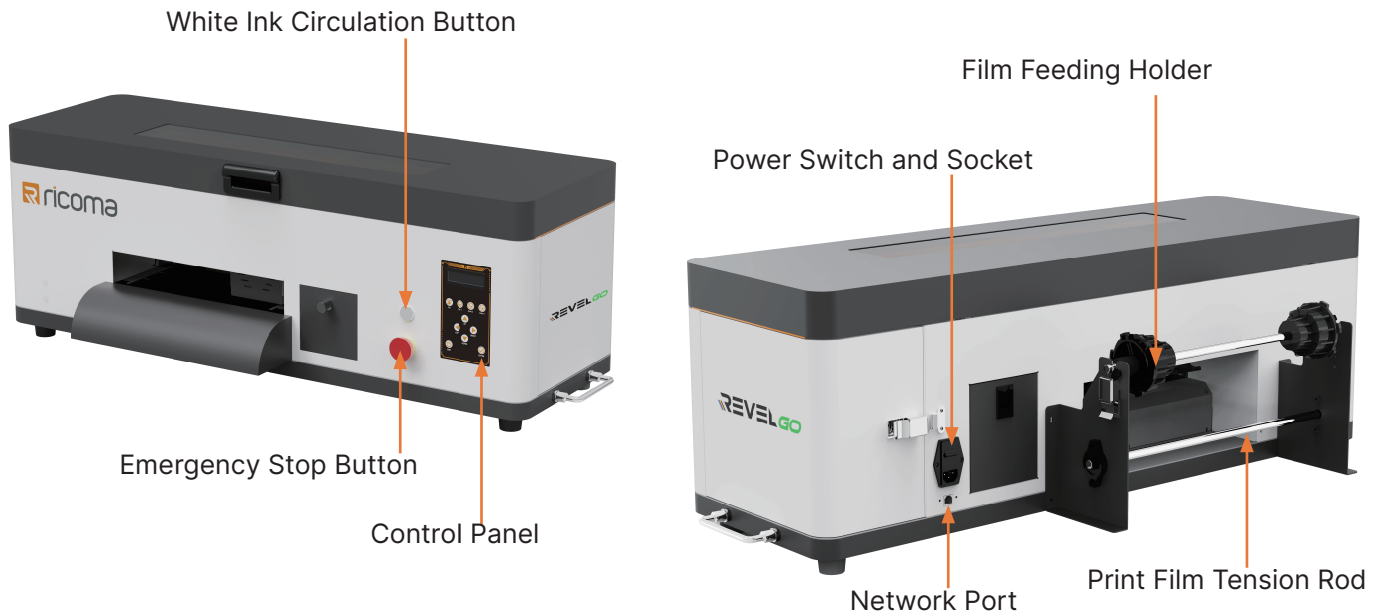

2.2 Overall Appearance Structure Diagram



2.3 Carriage Structure Diagram

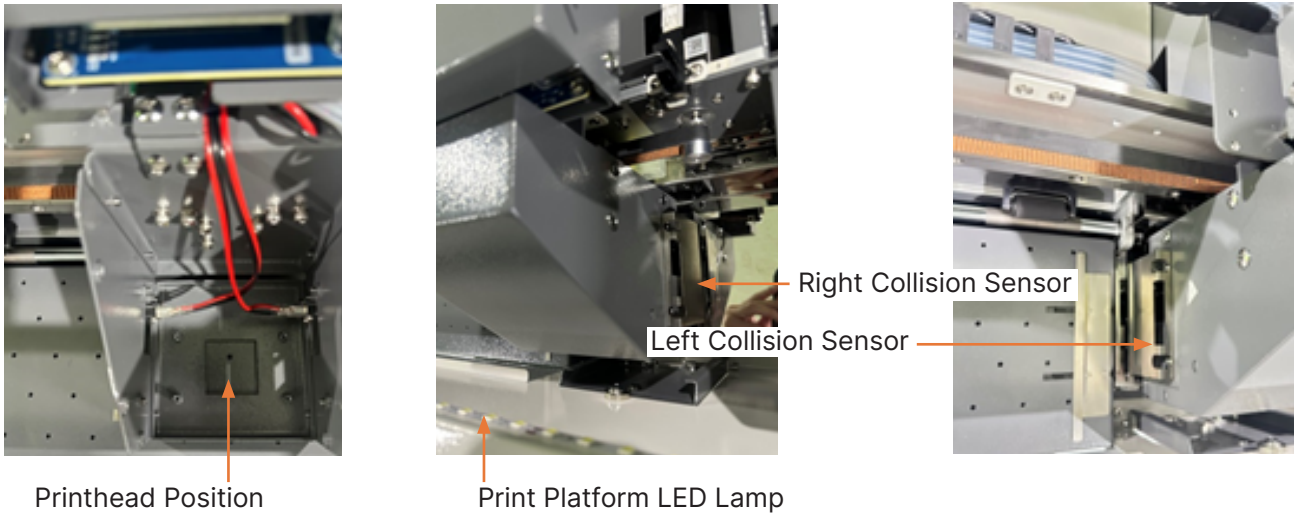

2.4 Left-Side Interior View of the DTF-1201E Printer

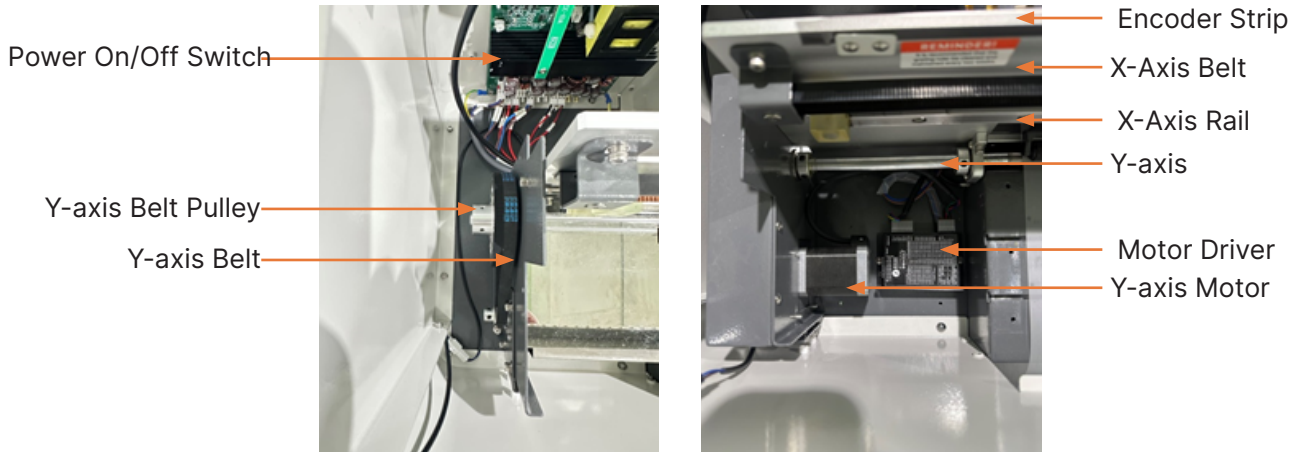

2.5 Right-Side Interior View of the DTF-1201E Printer

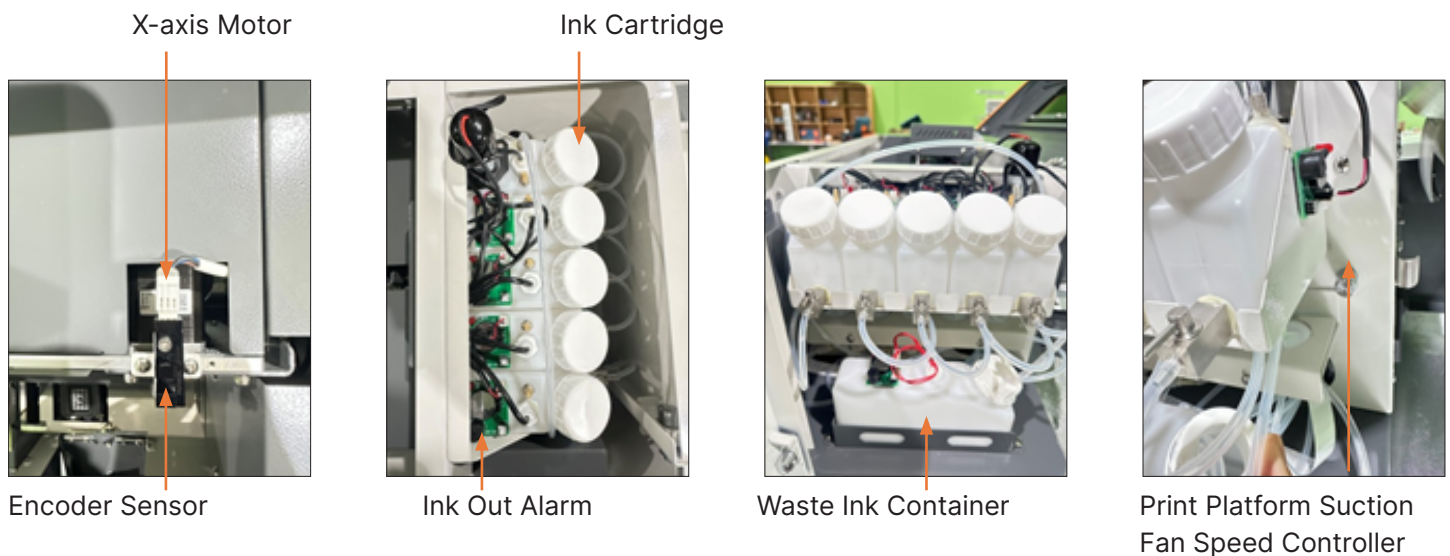

Chapter 3 Printer Basic Parameters

3.1 Basic Parameters

Model	DTF-1201E
Printhead Type	F1080
Number of Printheads	1
Printable Area	≤300mm
Printing Configuration	Color + White(CMYK+WW)
Compatible Media	PET Heat Transfer Film
Print Speed / Resolution	12 pass 1.2 m ² /h ; 16 pass 0.8 m ² /h ; 720X1800DPI; 720X2400DPI
Ink Type	Aqueous (Water-based) Ink
RIP Software	RIIN (UV Version)
Color Management	ICC profiles or Density Curves
Operating System	System Windows 7 / 10 / 11
Carriage Collision Protection	Emergency stop sensors with collision detection installed at both ends of the carriage
Waste Ink Alarm	Automatic alert when waste ink bottle is full
Ink Circulation & Agitation	White ink system has independent power supply; supports timed circulation even when the printer is powered off
Low Ink Alarm	Automatic alert when ink level in bottle is low
Print Bed Lighting	LED illumination on print platform
Print Platform Suction Fan Speed Controller	Adjustable Platform Suction
Interface	Gigabit Ethernet
Operating Temperature	15°C-30°C
Operating Humidity	35%-70%
Rated Power Consumption	250 W
Power Input	50HZ/220V 10A- 50HZ/110V 20A
Net Weight	42 kg / 185.2 lbs
Gross Weight	64 kg / 141.1 lbs (including machine and package)
Machine Dimensions	(L)x (W)x (H): 1077 × 586 × 382 mm / 42.4 × 23.1 × 15.0 in
Packaging Dimensions	(L)x (W)x (H): 1140 × 755 × 425 mm/ 44.9 × 29.7 × 16.7 in

Chapter 4 Hardware Installation

4.1 Introduction to the Printing System

The DTF-1201E printing control system consists of three components: the main board, the printhead board, and the control software. It connects to a PC via a USB 2.0 port.

4.2 Printer Control Board Interface Definition

Board Interface Connection Sequence: Power first, followed by high-speed communication interfaces, low-speed communication interfaces, and finally control interfaces.

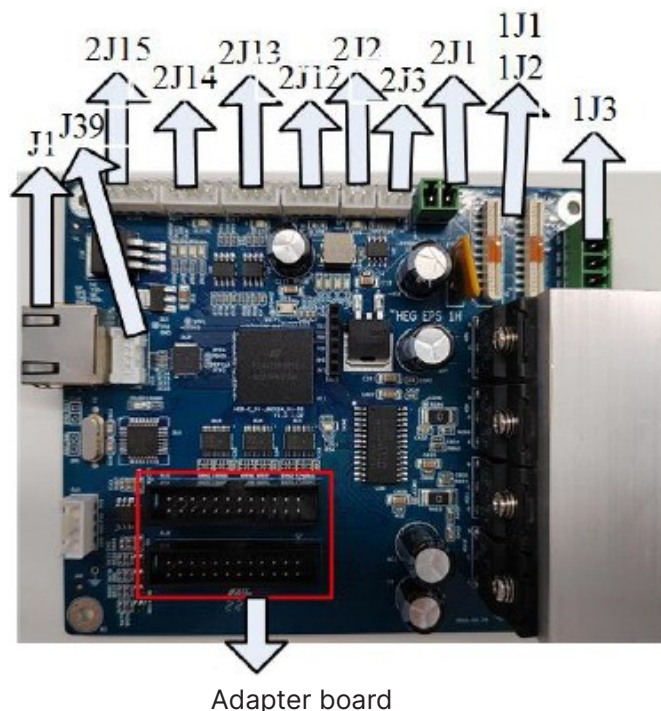

No.	Interface Definition
J1	RJ45 Cable Communication Port
J39	5-pin Cable Communication Port
2J15	Encoder Strip Interface
2J14	Left Limit Switch Port
2J13	Right Limit Switch Port
2J12	Film Sensing Interface
2J2	Collision-proof Interface
2J3	10K NTC Thermistor Feedback Port
2J1	Heated Bed Interface
1J1, 1J2	FPC (Flexible Printed Circuit) Power Interface
1J3	Power Input Port

4.3 Nozzle Configuration

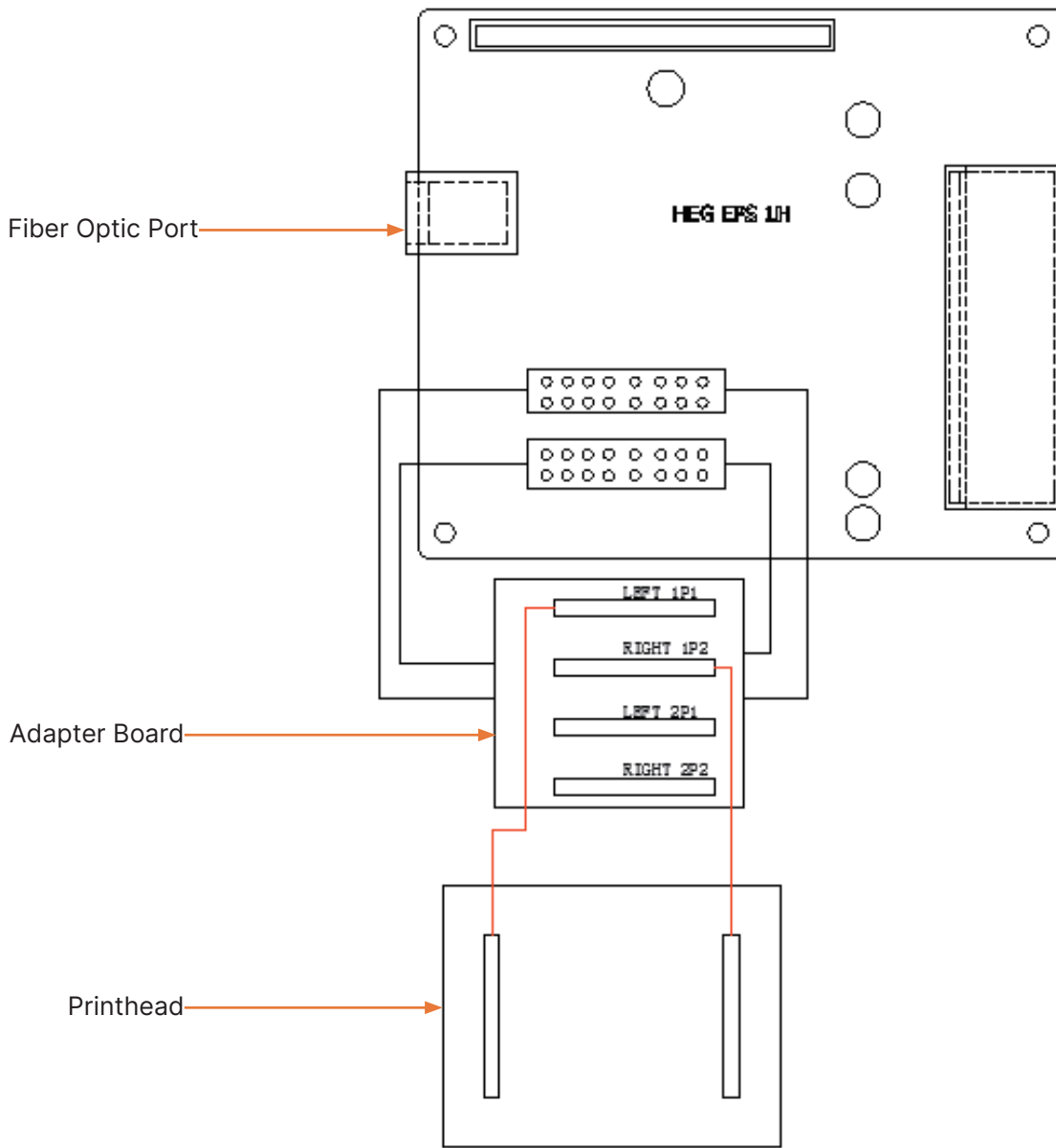

4.4 Motherboard Interface

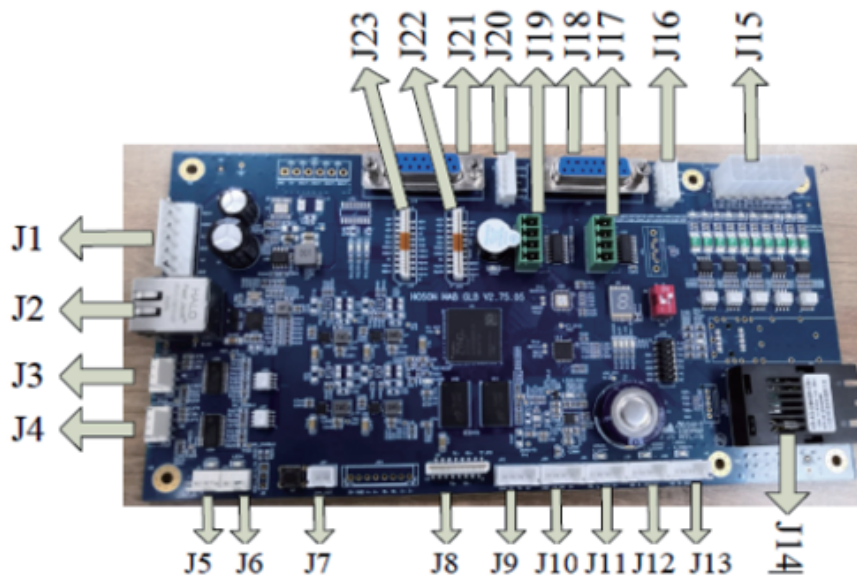

4.5 Motherboard Wiring and Pin Definitions

Note: The motherboard design requires dual 24V power inputs for stable operation, and must be securely fastened to the machine chassis with screws.

Board Interface Description: Sequence is as follows: power, high-speed communication interface, low-speed communication interface, control interface.

No.	Interface Definition	No.	Interface Definition
J1	Power supply (24V/42V) input interface	J13	Low paper signal detection interface
J2	Gigabit Ethernet interface	J14	Fiber optic interface
J3	Ink stack lift motor interface	J15	224V control signal output interface
J4	Ink stack scraper motor interface	J16	Y-axis motor limit interface
J5	Ink stack scraper motor limit interface	J17	Y-axis motor single-output interface
J6	Ink stack lifting motor limit interface	J18	Y-axis motor differential signal output interface
J7	Ink supply reset interface	J19	X-axis motor single-ended signal output interface
J8	Control panel interface	J20	X-axis motor limit interface
J9	RS485 expansion interface	J21	X-axis motor differential signal output interface
J10	Grating Signal Input Interface	J22	24V flat cable power supply interface
J11	Left limit interface	J23	24V flat cable power supply interface
J12	Right limit interface	J24	

4.6 Printer Board Installation and Wiring Diagram

The printer control system consists of three components: the main board, the printhead board, and the control software. It connects to the computer via an Ethernet port.

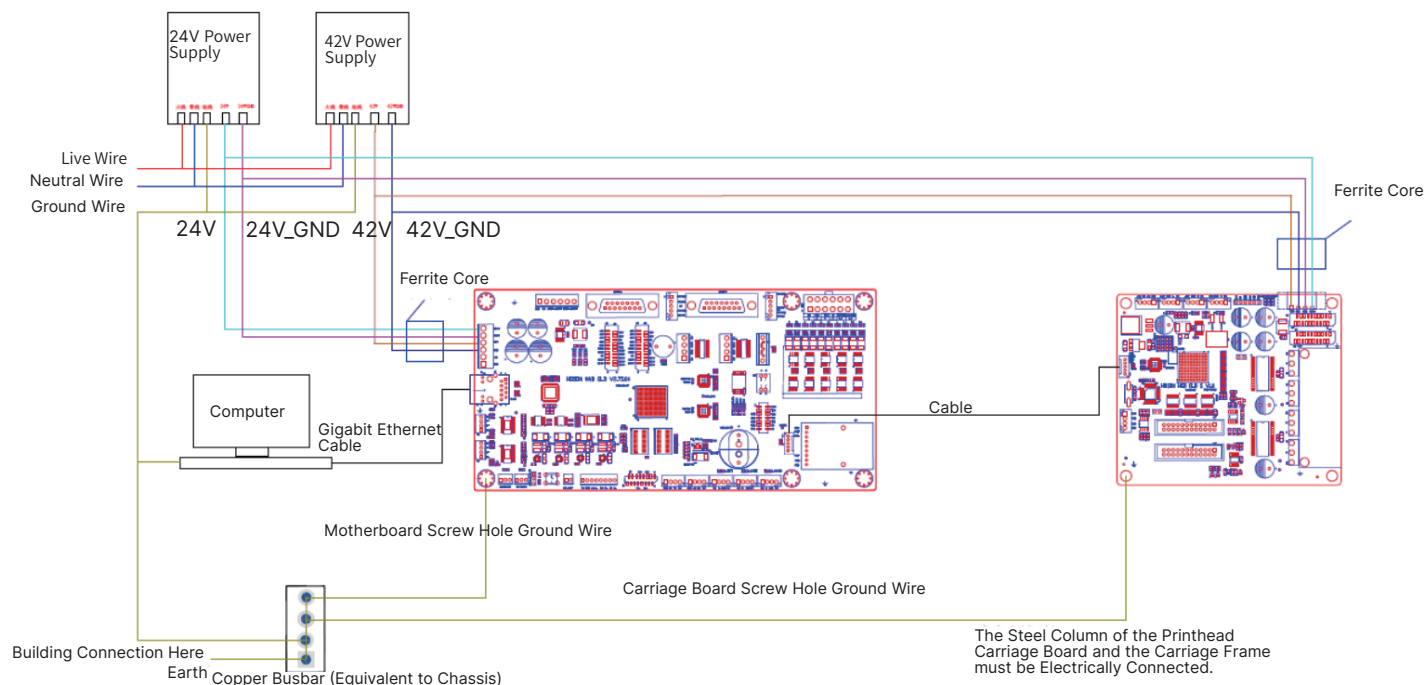

Chapter 5 Software

Print Exp_X64 software is a kind of printer management software, which is mainly used to set various printer parameters, calibrate and adjust printer nozzles, maintenance, nozzle cleaning and printing operation, etc. All operations are performed using Print Exp_X64.

5.1 Software Installation

The printing management software shall be installed according to the following steps:

As the existing computer systems include Win7, Win10, Win11 etc., the installation steps are as follows:

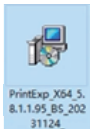
1. Elect the Print Exp_X64 software icon:  , right-click and select "Run as administrator".

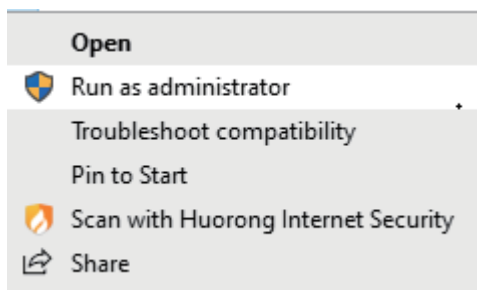

2. Select the desired language version (Chinese or English), and click OK.

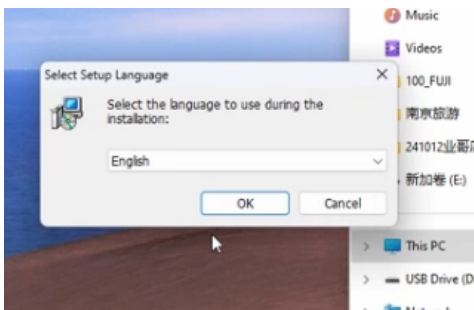

3. Select the installation disk location: Install components; LINK TCP is selected by default.

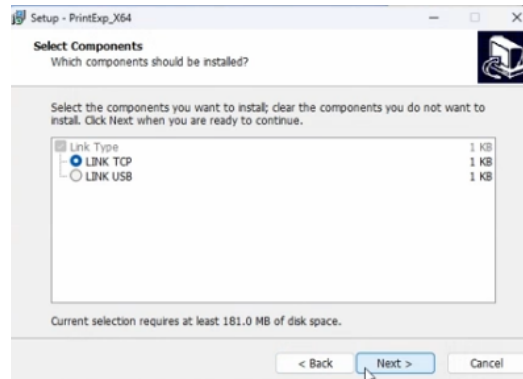
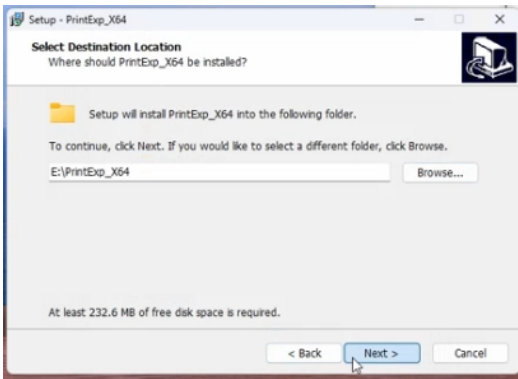

4. Select the shortcut location in Start Menu Folder and choose to create a desktop icon.

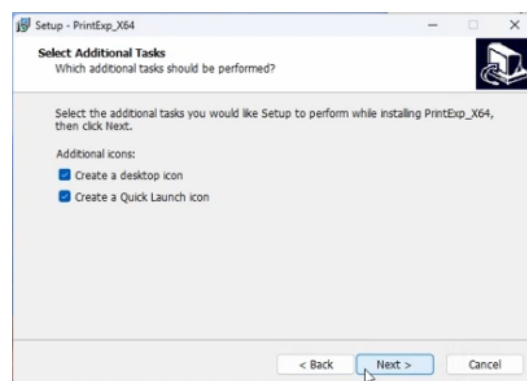
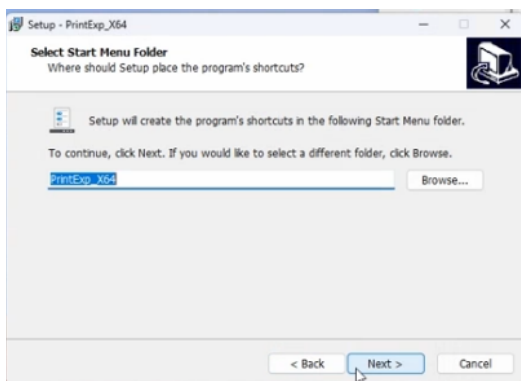

5. Install the Print Exp_X64 software, clicking "Next" in pop-up windows until completion.

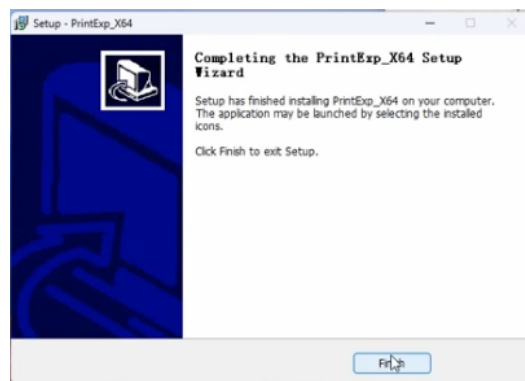
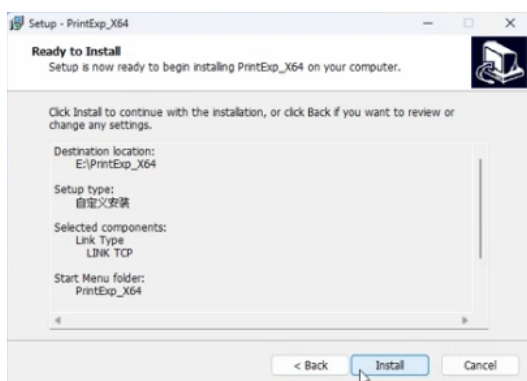

6. Open the unpacked folder, double click  Print Exp_X64.exe to enter the main interface of the software, as shown in below figure:

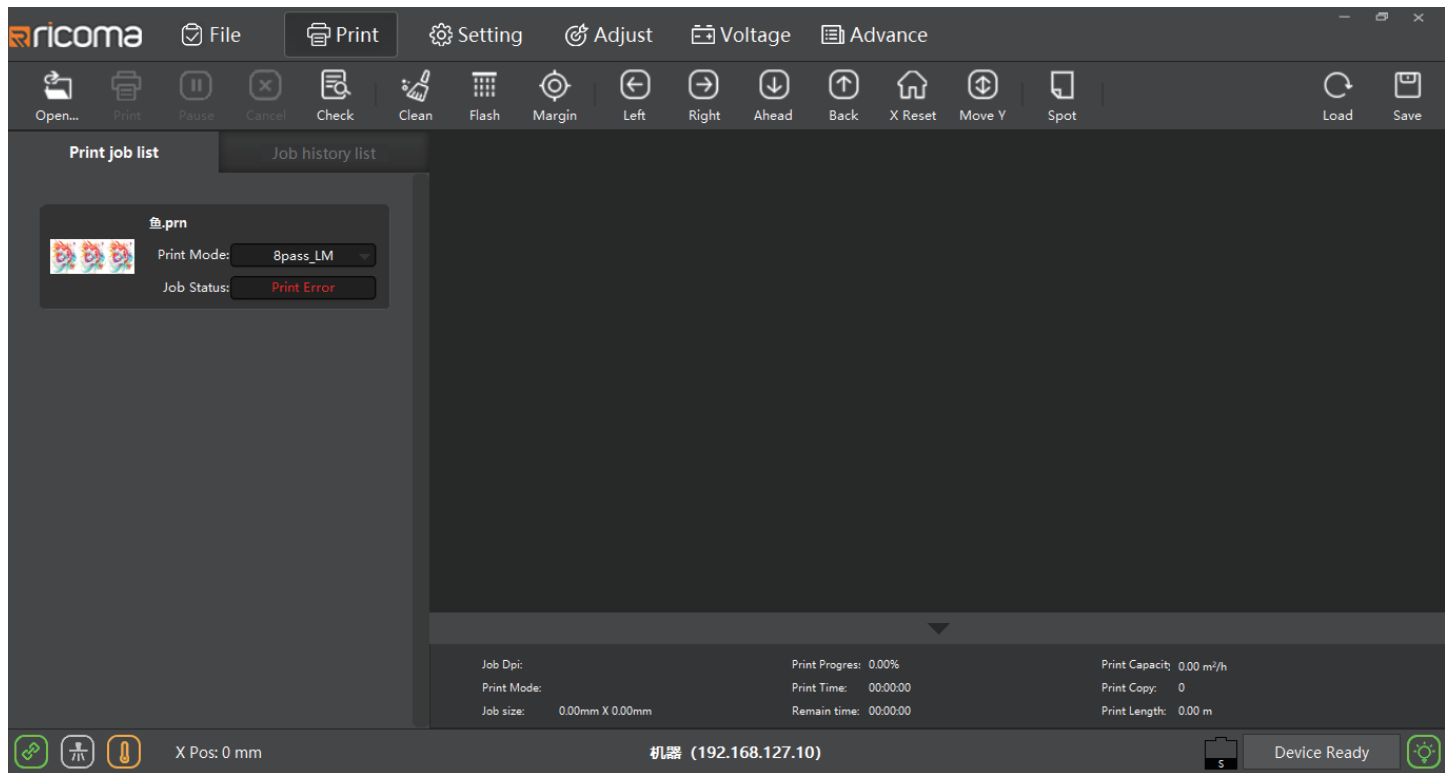

Chapter 6 Nozzle Installation

6.1 Carriage Board Printhead Arrangement

Printhead left

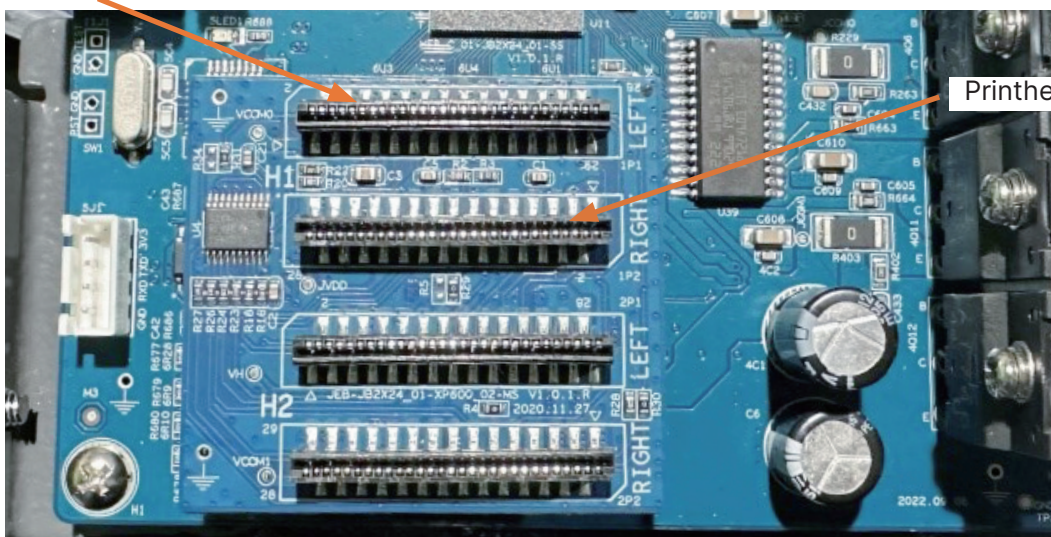

Printhead right

6.2 Printhead Data Cable Connection Methods

Note: Regardless of how the printhead board is installed, this connection is unique.

Reversing it may burn out the printhead or the board

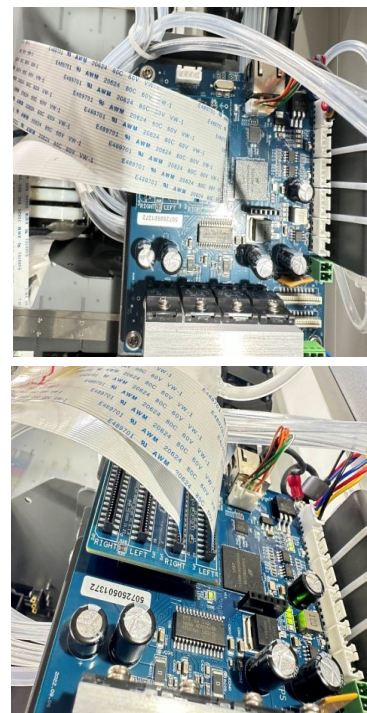
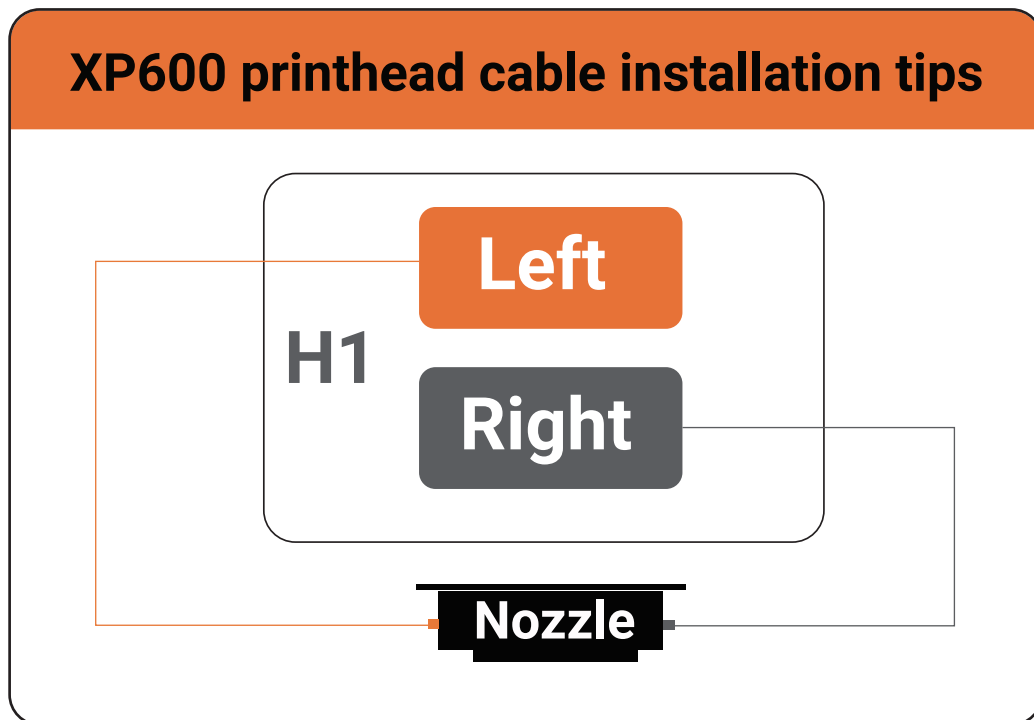

EPSON F1080
Printhead



Arrangement of
Nozzles in the Ink
Supply Tube



Nozzle Data Cable
Connector

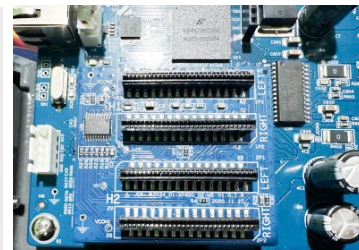

Spray Gun Panel Data
Cable Connector



Gigabit Ethernet Cable

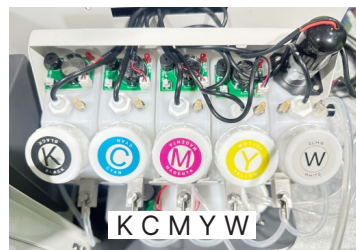

Ink Cartridge
Arrangement



Ink Sac (6 required per
printhead)

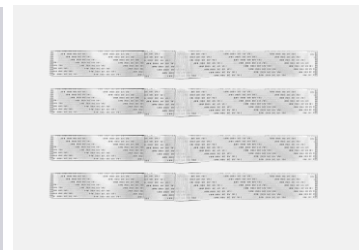

One Printhead Require
2 Date Cables to
Connect to the Head
Board

Chapter 7 Computer Connection Settings For Printing Software

7.1 Set Computer IP Network

Right-click on the Network icon and select Properties → Select Local Connection, right-click Properties to open this interface

Set up the computer to connect to the network and use the customized IP address: 192.168.127.58, subnet mask (default): 255.255.255.0.

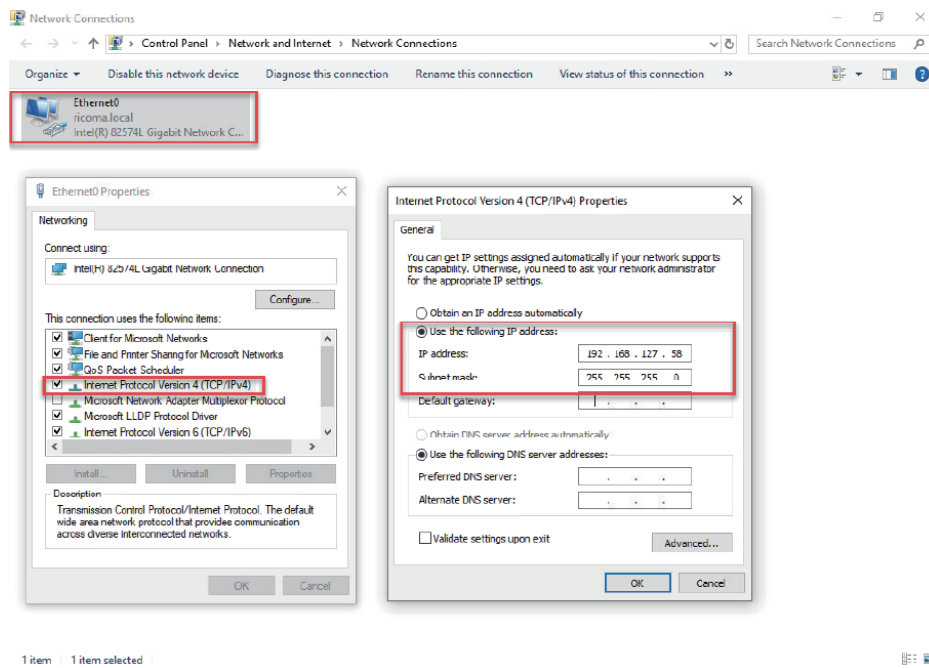

7.2 General Software Settings

Click Settings to access general printing settings.

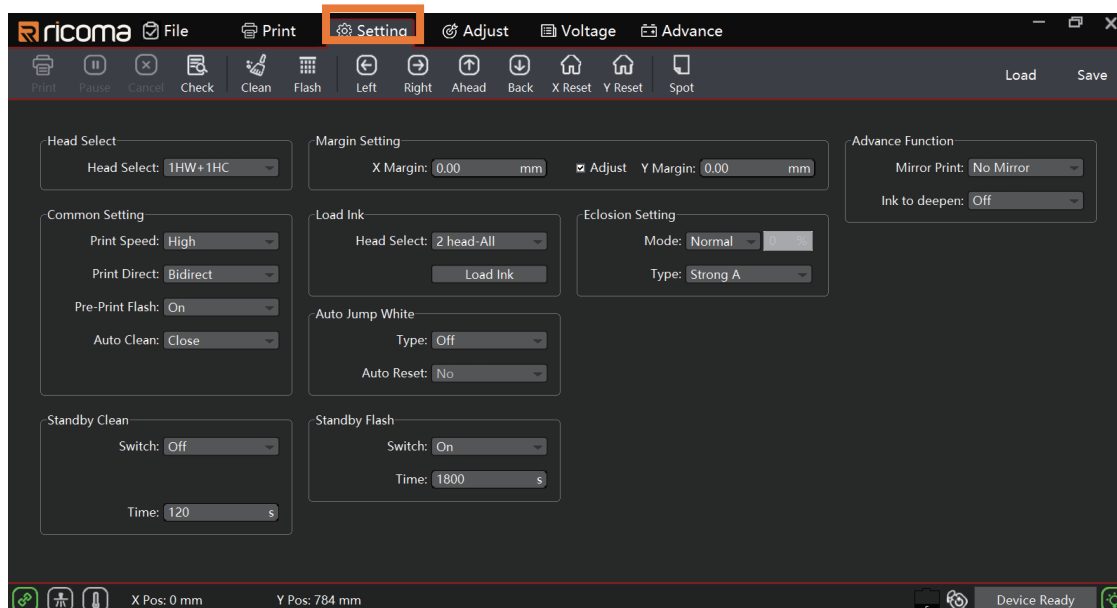

No.	Name		Function explanation
1	Nozzle selection		The nozzle selection setting is only available under specific model conditions
2	White border setting	White border on X	Set the starting position for printing
		White border on Y	Set the starting position for printing
3	general setting	printing speed	Set the print speed to low speed, medium speed and high speed
		Printing direction	Set the print direction to print to the left, print to the right, and print in both directions
		Pre-printing-flash spray	Set whether to flash before printing
		self-cleaning	Set it to be on or off before printing
		Paper Feed Direction	Paper Feed Direction Option
4	Color Bar Settings	Color Bar Position	You can set the color bar position to output on the left side, output on the right side, output on both sides, or turn off the color bar, respectively
		Color Bar Mode	Choose the mode of the color bar during printing
		Color Bar Density	Select the density of the color bar when printing, with options including Low, Medium, and High
		Color Bar Width	Specify the width of the color bar for printing
		Color Bar Spacing	Set the distance between adjacent color bars during printing
5	Feathering setting	Feathering mode	Feathering mode selection
		Feathering type	Selection of feathering type
6	Advanced Function	channel control	Control the nozzle data
		Mirror print	Control whether the picture is printed horizontally flipped
7	Light		Ink Drying & Curing
8	Automatic white jump	Jumping white method	Select the whitespace mode, including off whitespace, step whitespace, and continuous whitespace
		automatic reset	Choose whether to reset automatically

Go to Advanced Settings → Manufacturer Settings → Password 111111, enter the internal function Settings

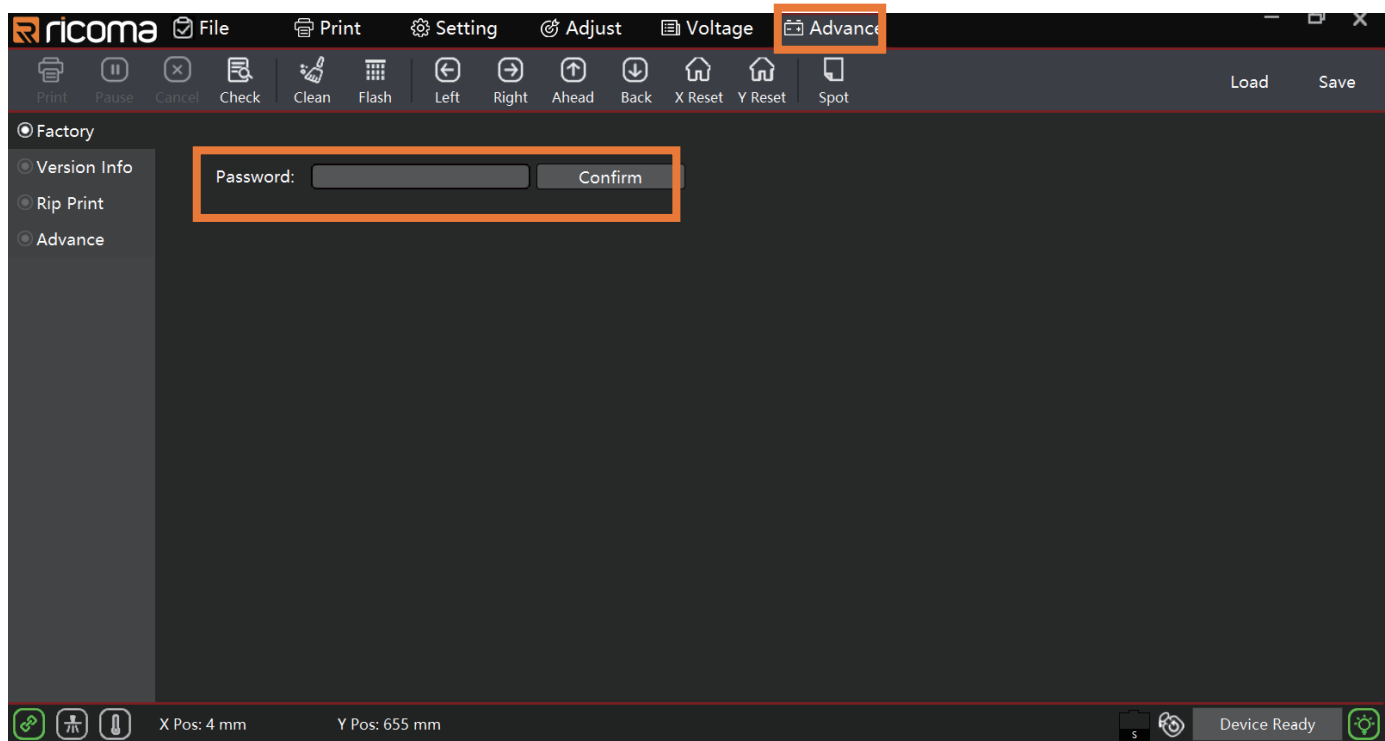

Click on the ink stack to mainly set the position parameters of the ink stack. You can set the head height, cleaning height, ink scraping height, etc.

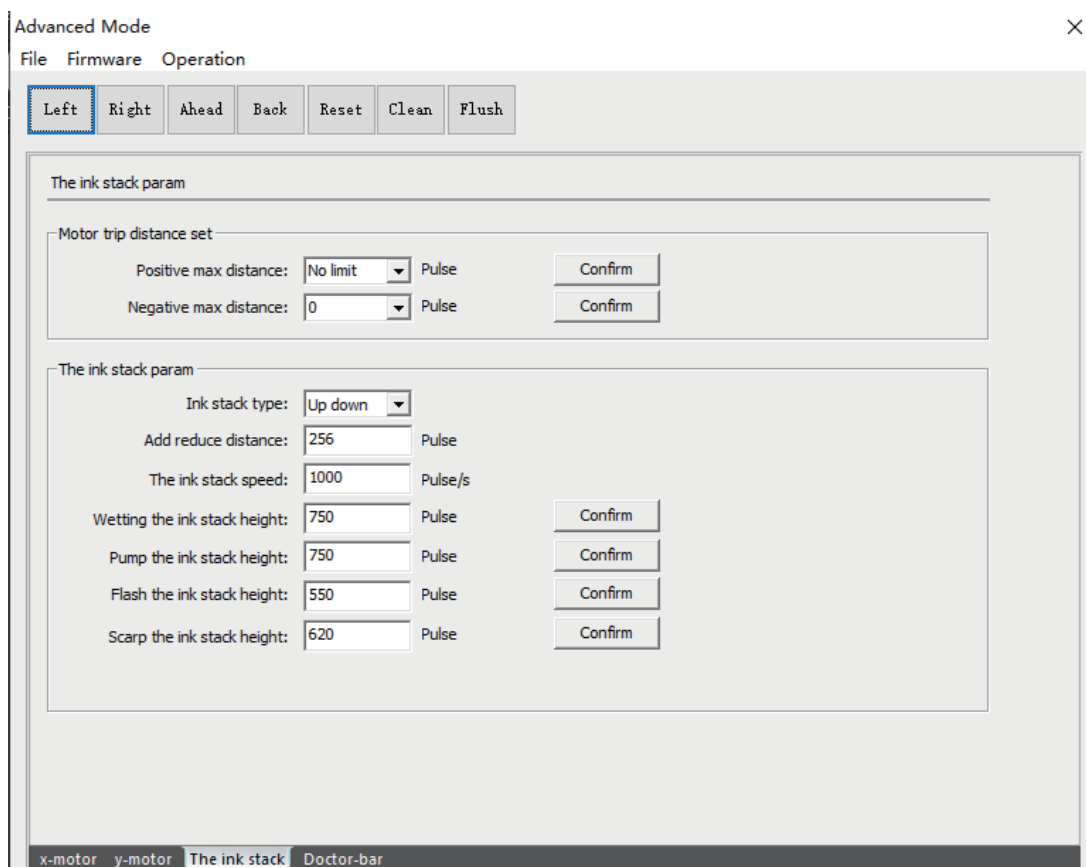

Manual cleaning. Parameters can be adjusted here for the cleaning process. Other functions can be left at their default settings.

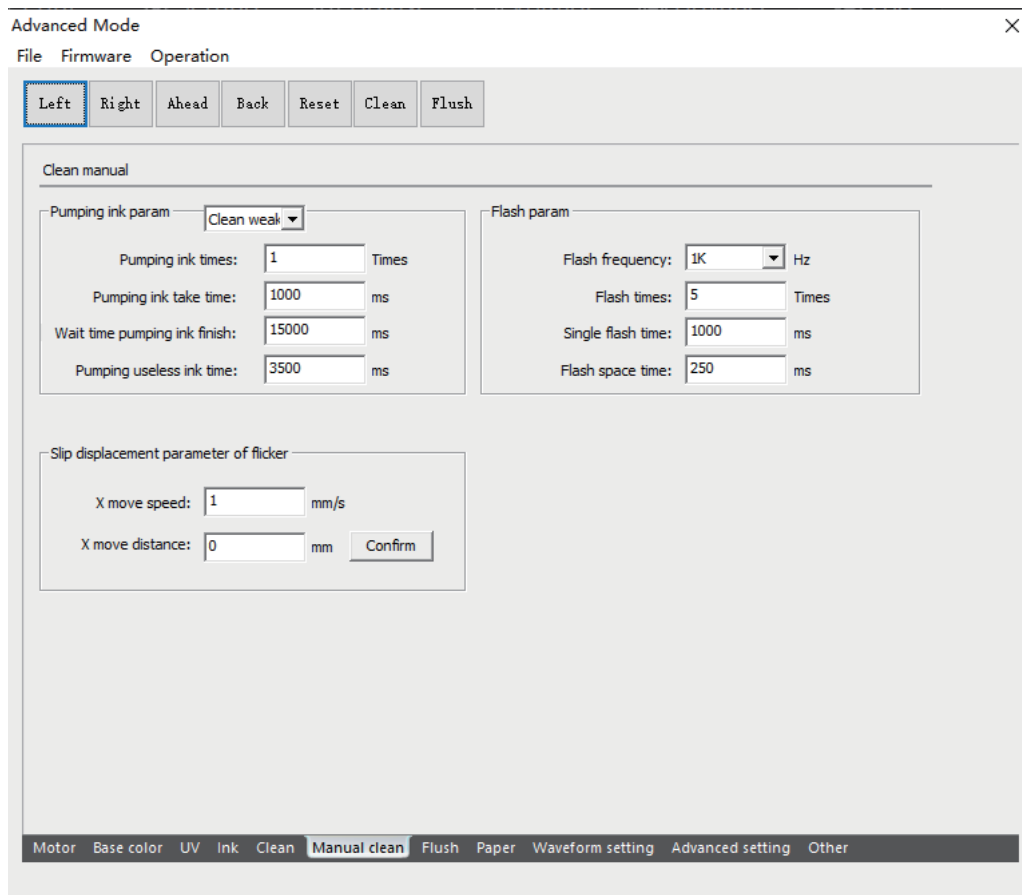

7.3 Control Panel Description

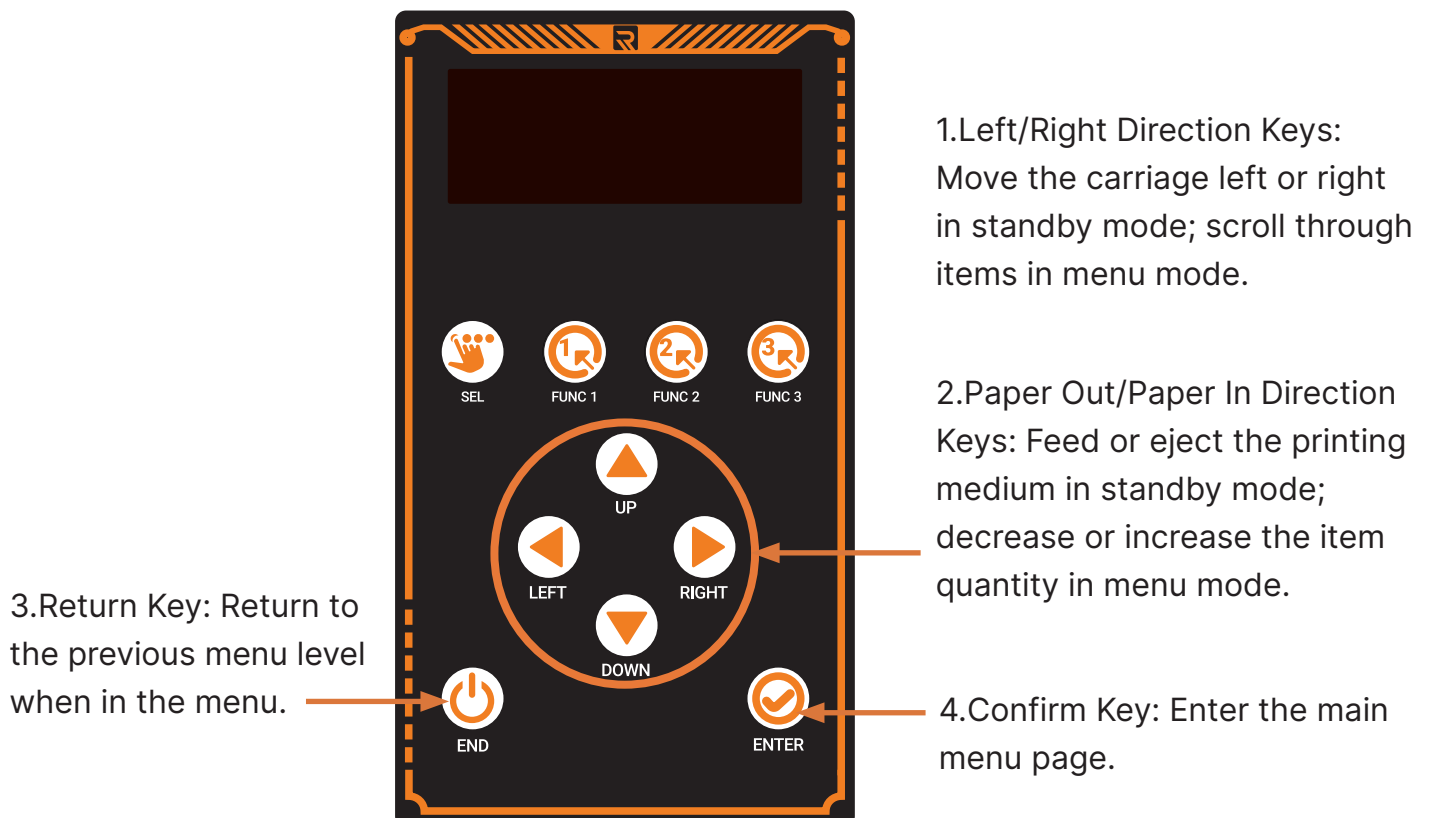

Chapter 8: Procedures for Printing Calibration Adjustment

8.1 Introduction for Nozzle Detection Function

Click "Nozzle Detection" to print the nozzle test strip. The sample is as follows

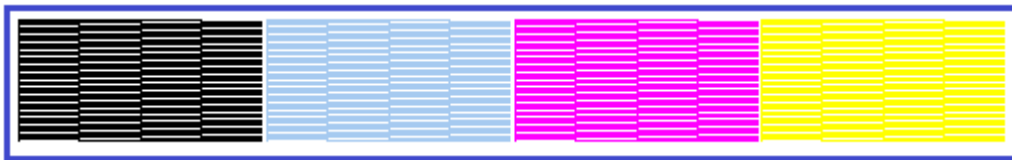

Nozzle calibration figure

Magnify the normal and abnormal conditions of the black state diagram as shown in the following figure:

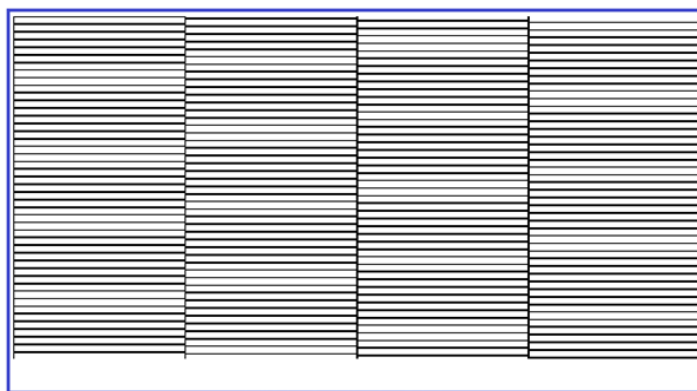

Normal nozzle status figure

The state diagram in the following situation may be clogged and needs to be cleaned until the inkjet from the spray holes reaches the best state

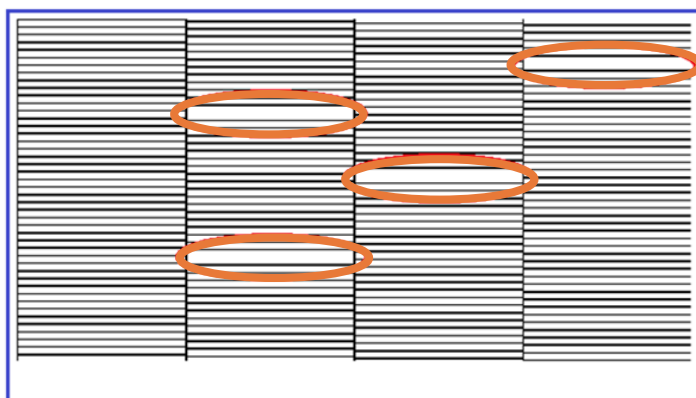

Abnormal nozzle status figure

8.2 Stepping Calibration Function

Click "Step Calibration" to print

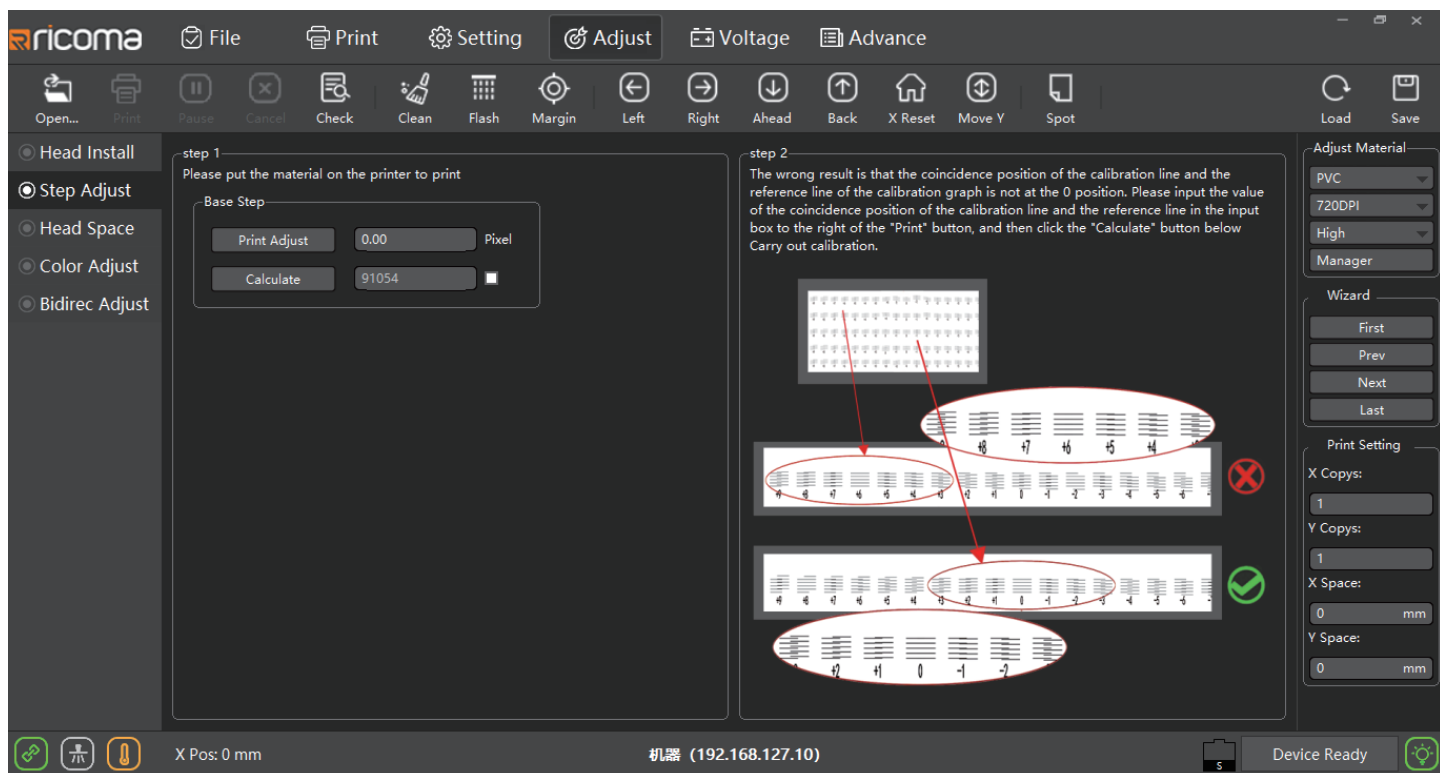

If the step adjustment is normal, the baseline and the scale mark will completely overlap at zero. As shown in the step adjustment status Figure 1.

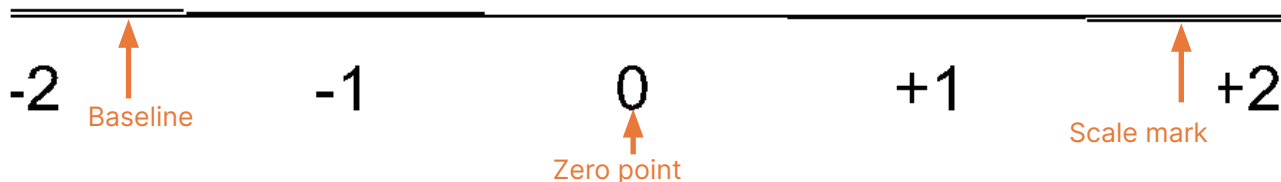

Step adjustment status figure 1

If the step adjustment is abnormal, the baseline and the scale marks will not overlap. As shown in the step adjustment status Figure 2



Step adjustment status figure 2

In this case, adjustments are needed. First, enter the adjustment value, click to calculate and reprint the print pattern until the baseline and the scale mark completely overlap at zero.

8.3 Calibration of the Horizontal Spacing of Nozzles

Click "Nozzle Spacing" to print.

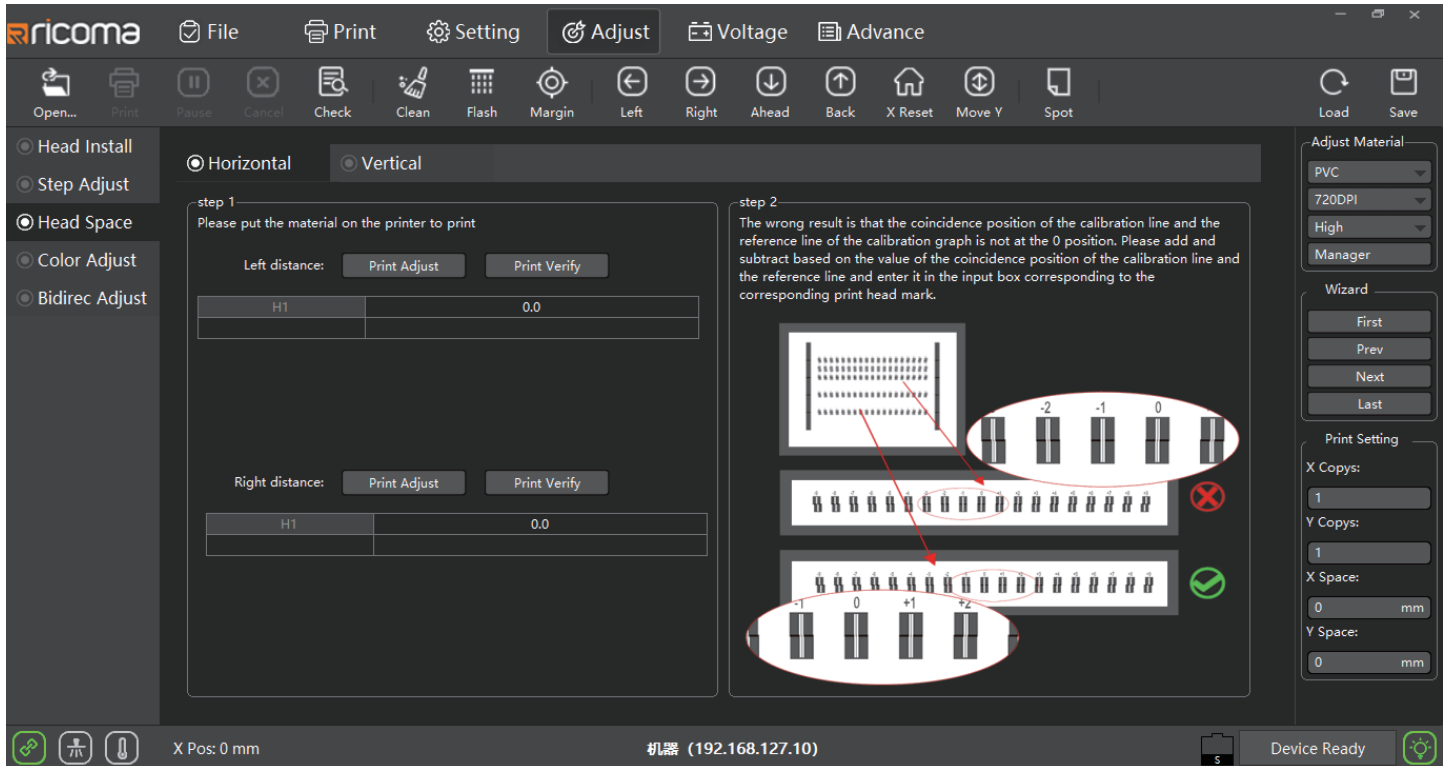

If the print head spacing is properly aligned, the printed pattern will be as follows.

Figure 1 shows the alignment state of the horizontal spacing of the nozzles.

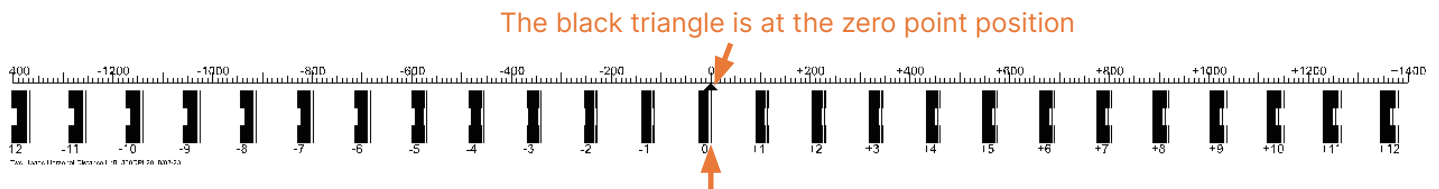

The line pointed by the zero point arrow is overlapped

Nozzle horizontal spacing alignment state figure 1

If the print head spacing is abnormally aligned, the print pattern will be as follows.

Figure 2 shows the alignment state of the horizontal spacing of the nozzles.



The two black sections on the left and right do not overlap each other

Nozzle horizontal spacing alignment state figure 2

In this case, it needs to be aligned. First, enter the adjustment value at position H2, click to calculate and reprint the print pattern until the zero point in the scale line is zero to zero.

8.4 Calibration of Longitudinal Spacing of Nozzles

Click "Nozzle Calibration" to print.

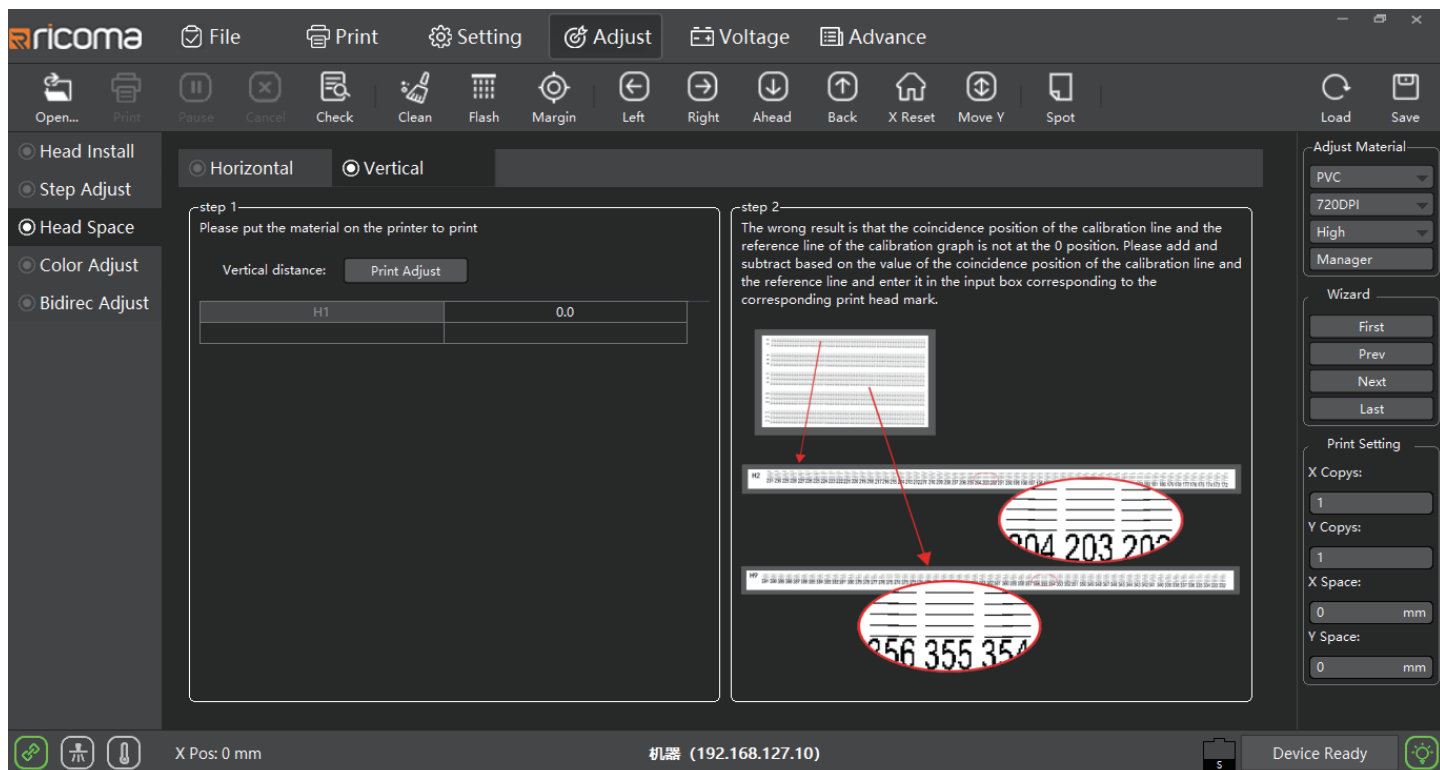

If the longitudinal spacing alignment of the nozzles is normal, all the lines in the zero point scale frame are parallel, and the left arrow points to the zero position. Figure 1 shows the alignment status of the print head longitudinal spacing.

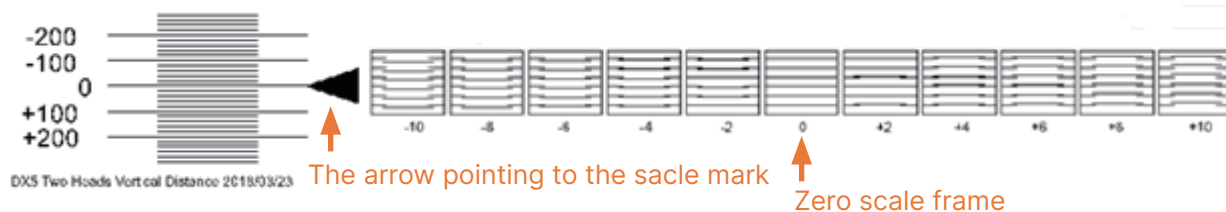

Figure 1 shows the alignment state of the longitudinal spacing of the nozzles

If the longitudinal spacing of the nozzles is adjusted abnormally, all lines in the zero point scale frame will be parallel to the -4 position. It is displayed as the longitudinal spacing alignment of the nozzles

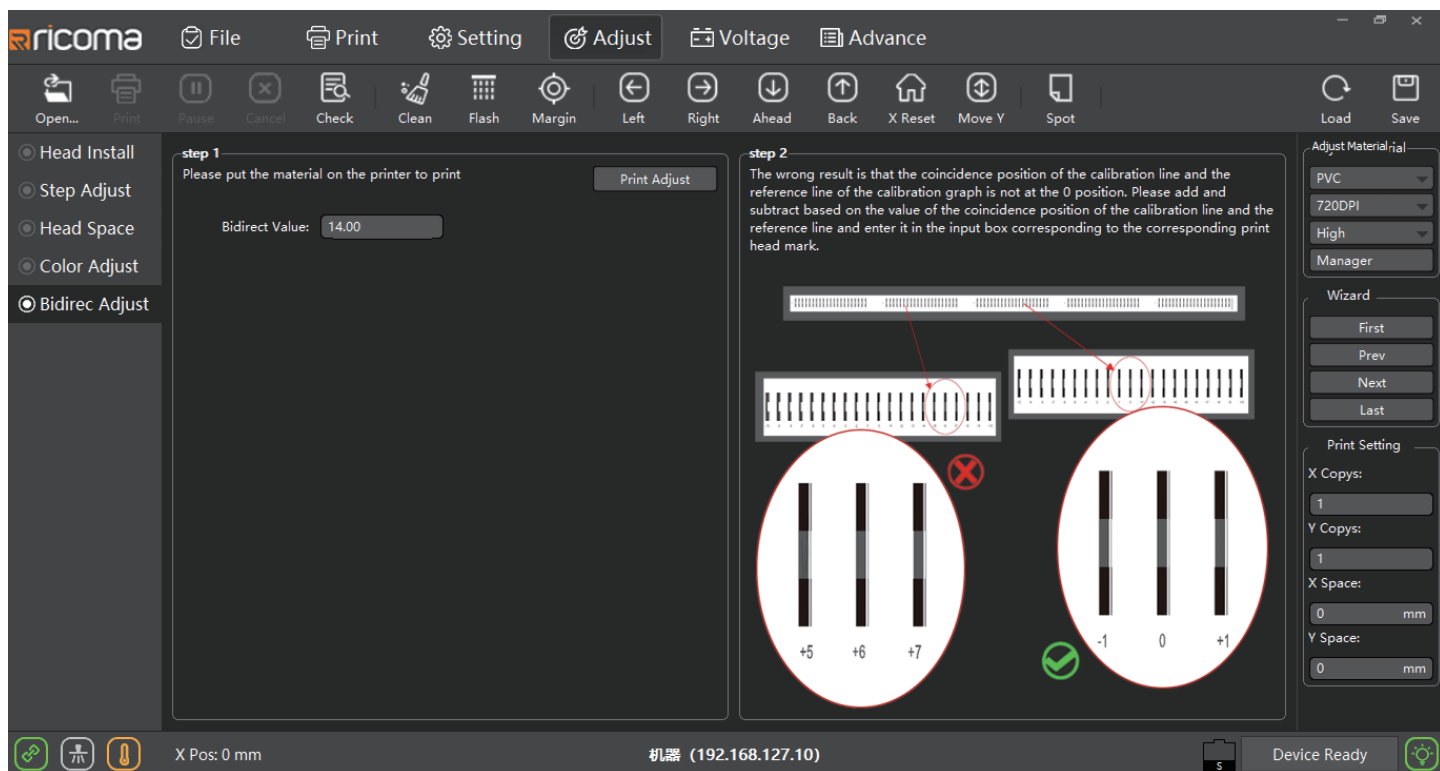

Figure 2 shows the alignment state of the longitudinal spacing of the nozzles

In this case, adjustments need to be made based on the original adjustment reference until all lines in the zero point scale frame are parallel at zero and the left arrow points to the zero position.

8.5 Bidirectional Calibration

Print "Print Calibration Diagram" in single-machine bidirectional calibration



If the bidirectional calibration is normal, the lines will overlap at the zero position as shown below.

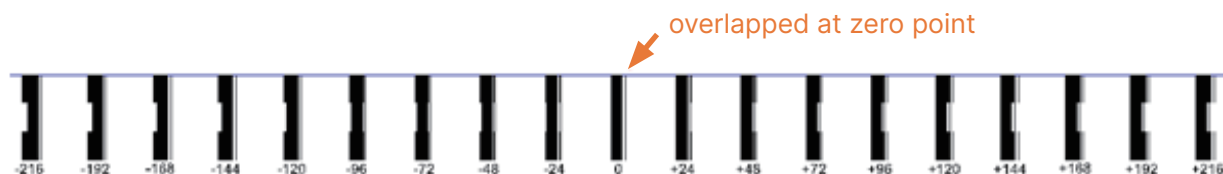

Bidirectional calibration status figure 1

If the bidirectional calibration is abnormal, the circuit will not overlap at the zero position, as shown below

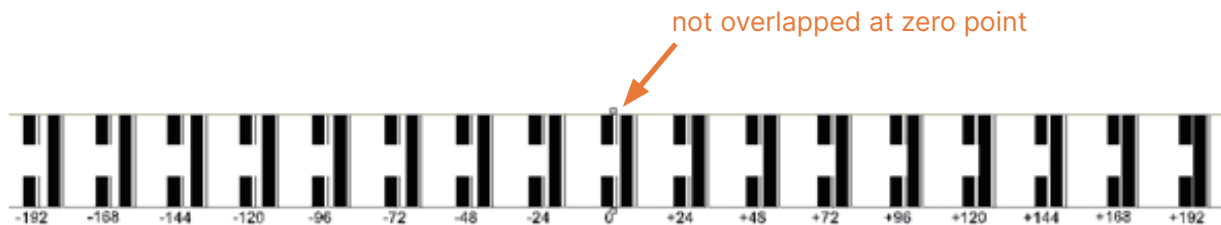

Bidirectional calibration status figure 2

In this case, it is necessary to input the adjustment values for readjustment.

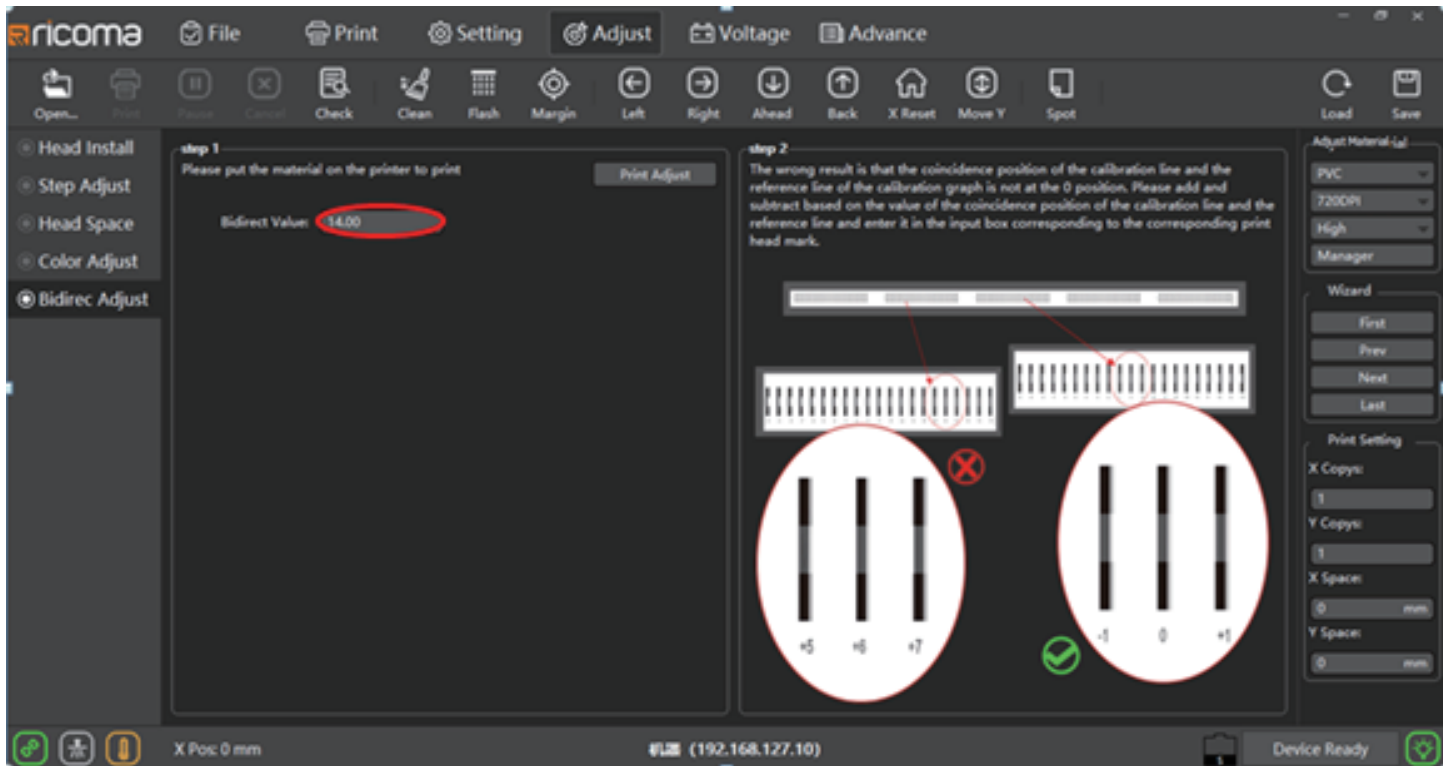

8.6 Color Calibration

Click on "Print Left/Right Calibration Diagram" under the color registration calibration interface to print the calibration diagram.

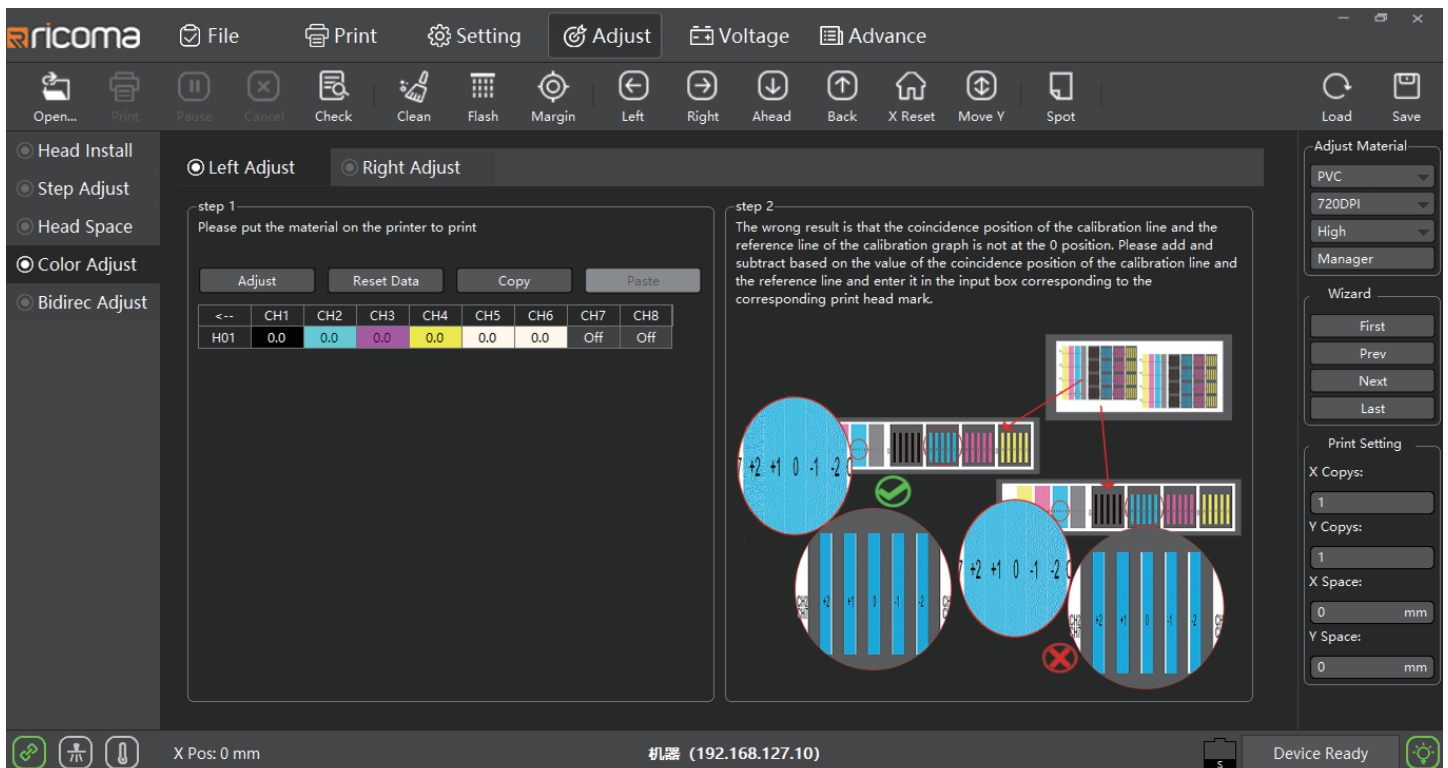

If the color adjustment is normal, the lines will overlap at this zero position, as shown below.

At zero point, the color pattern of this channel exactly coincides with the black pattern

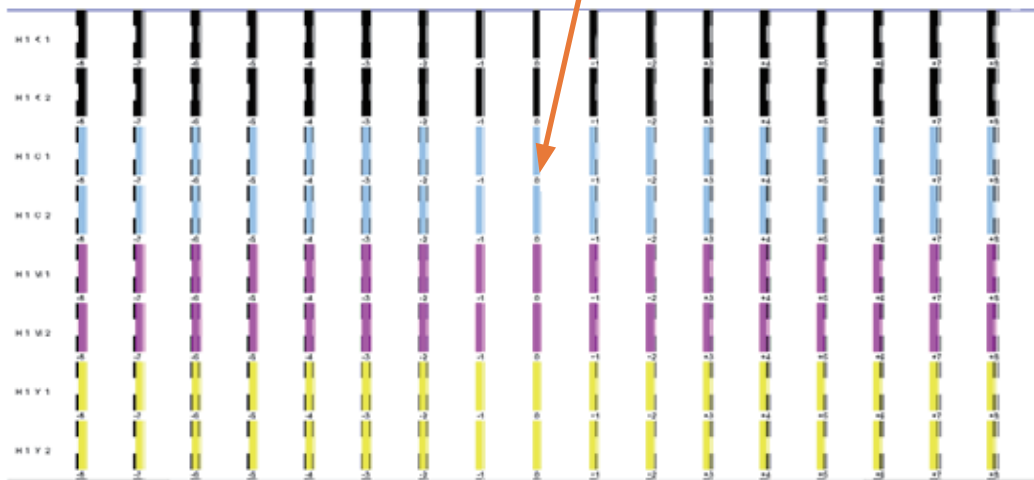

Color registration calibration figure 1

If the color adjustment is abnormal, the lines will not overlap at the zero position as shown below.

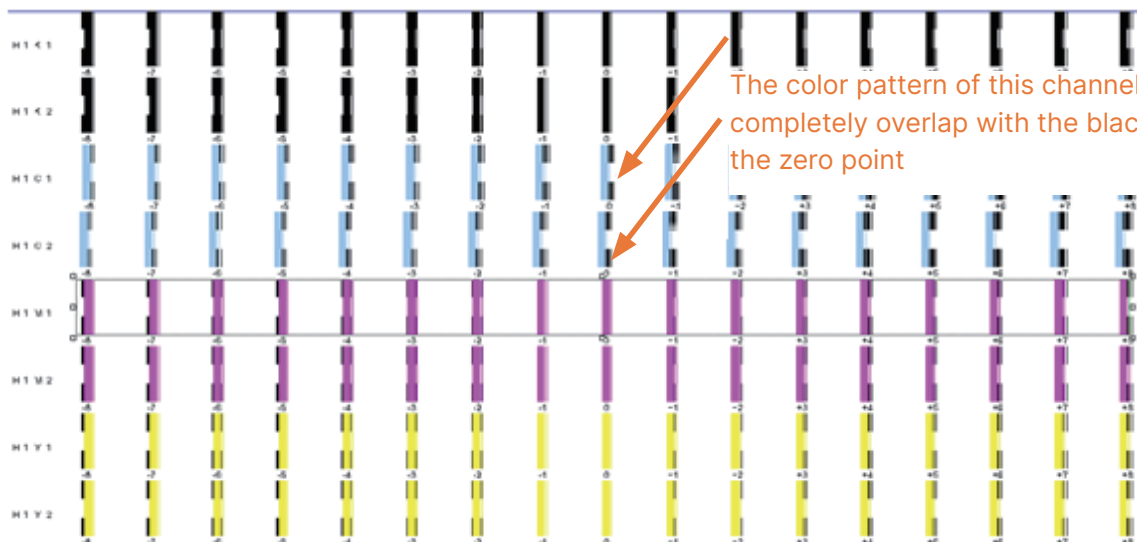

The color pattern of this channel does not completely overlap with the black pattern at the zero point

Color registration calibration figure 2

In this case, the adjustment value needs to be entered for readjustment, as shown in the figure below:

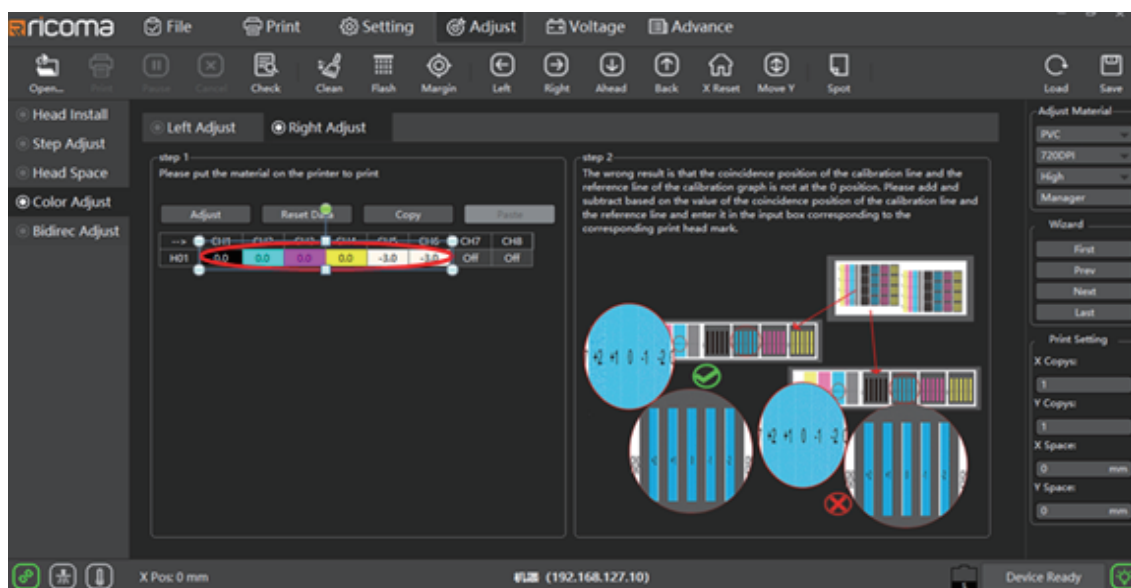

Chapter 9: Installation and Usage of RIIN Software

9.1 RIIN Installation

1. Take out the USB drive of the RIIN software and insert it into the computer to prepare for installing the software.

2. Right-click on the  /RIIN software installation package and select "Run as Administrator", Select the language you want to install (Chinese or English)



3. Use the RIIN installation wizard and accept the license agreement.

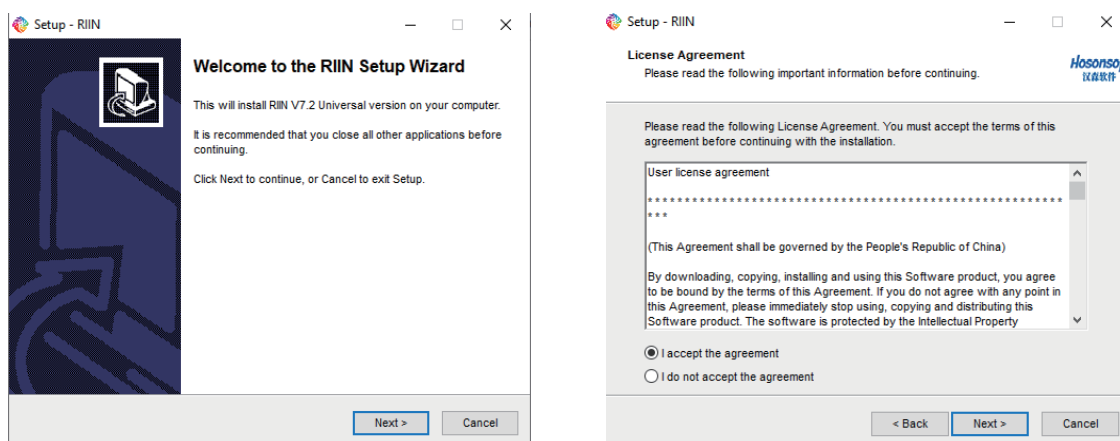

4. Read the software information and select the installation location of the software RIIN.

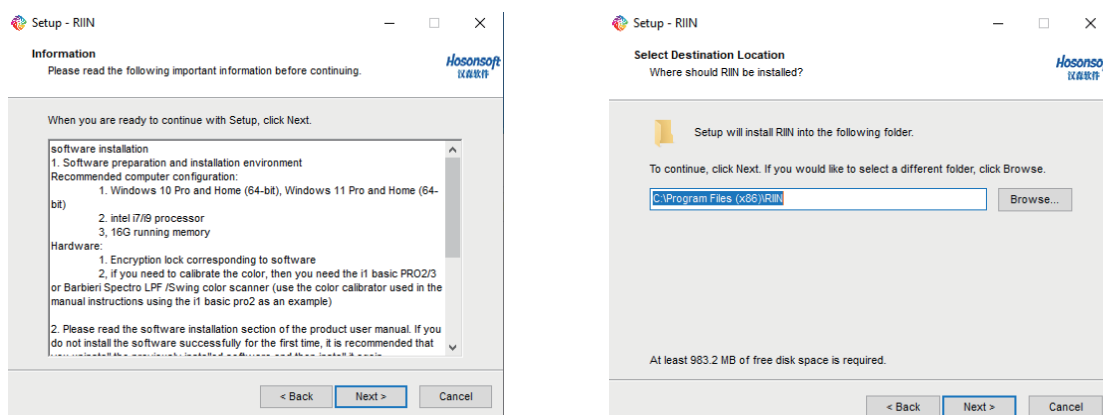

5. Select the file location in the Start menu and choose to create a desktop shortcut icon.

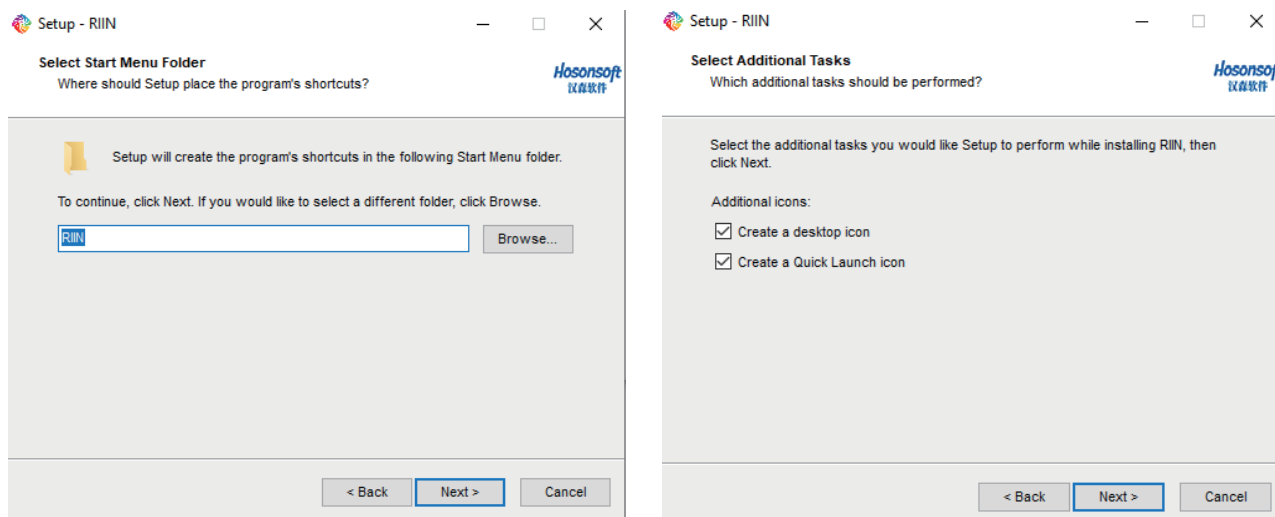

6. The software installation is complete

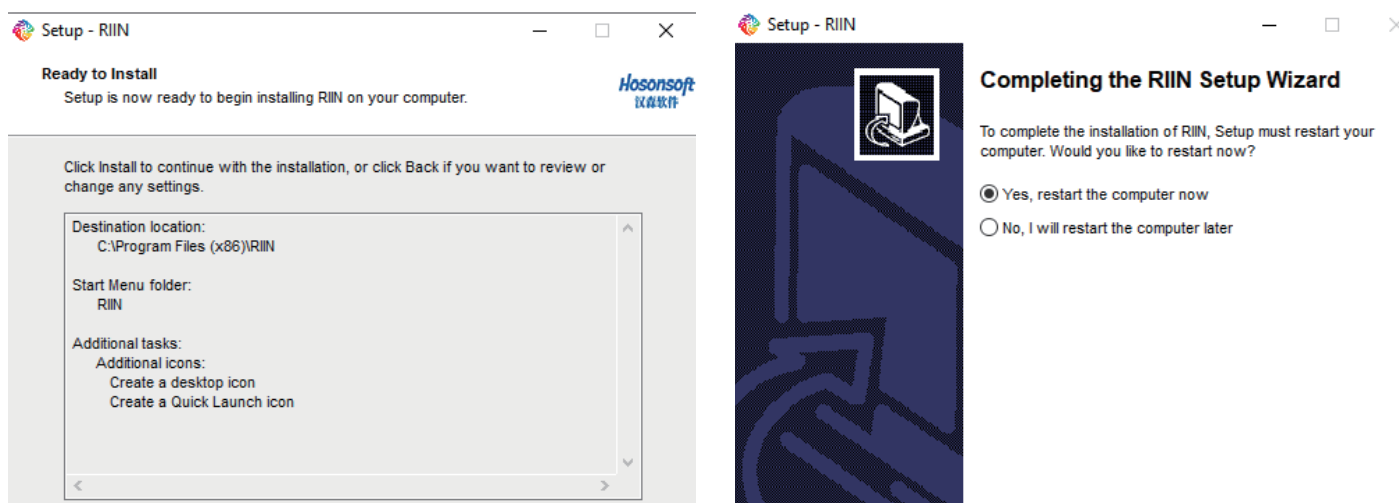

7. Insert the key, Double-click/RIIN.exe  on the computer desktop to enter the main interface, and the installation is complete

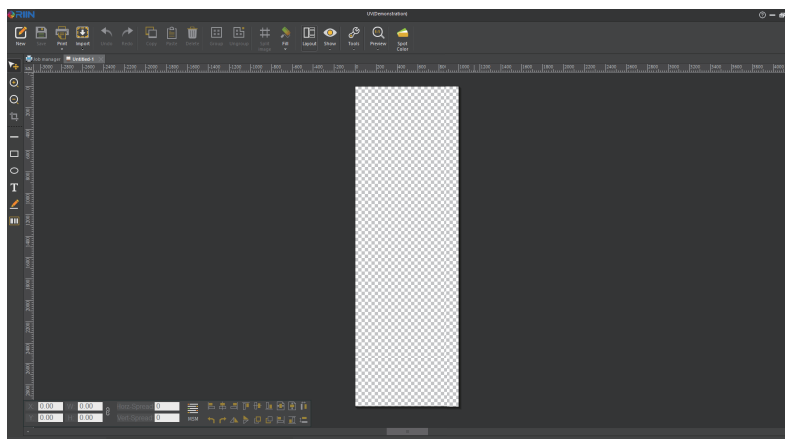

9.2 Introduction and Usage Instructions of RIIN Interface

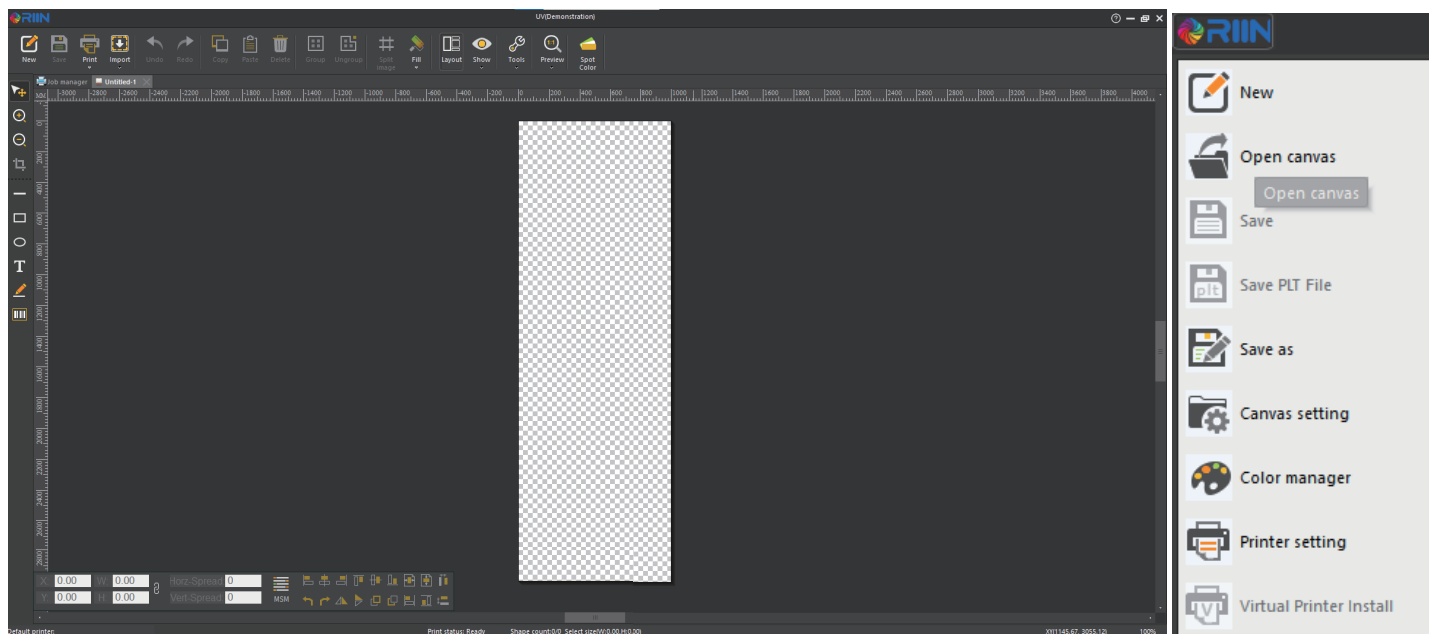

1. Instructions for Using Main Interface commands:

New	Create a new canvas	Import in	Import the picture to be printed
combination	Integrate multiple pictures into one	dissolve	Separate the combined pictures again
split image	Divide the picture into multiple pictures	Fill in	Fill in colors for the drawn closed graphics
composing	After clicking, convenient layout instructions and Settings for multiple images will appear in the lower right corner. Among them, the material-saving command can be used for automatic layout		
Display	You can select various displays on the interface	Tool	Settings and processing of auxiliary images
Full-page preview	Window mode and size selection	Spot color	Setting the model of colors
Print	Print the processed pictures		

2. Drop-down Command Usage Instructions

New	Create a new canvas	Open the canvas	Open the previously saved canvas
Canvas Setting	Set the canvas size, origin and edge white space	Color management	Select Curve
Printer Management	Import the printer and set the Default to "Default" in the drop-down menu		

Chapter 10 Maintenance Guidelines

1. Before starting printing each day, perform a nozzle check to verify whether the printhead is clogged. If the test pattern shows missing nozzles (skipped lines), clean the printhead immediately.
2. Operating environment: Temperature: 15°C – 30°C; Relative humidity: 35% – 70%
3. Before shutting down the printer each day, run a nozzle check. If any missing lines are detected, clean the printhead thoroughly before turning off the machine.
4. When powering off, ensure the printhead is properly aligned and fully seated onto the capping station (ink stack). There must be no gap between the printhead and the capping station.
5. During printing, enable color bars to prevent nozzle clogging caused by prolonged inactivity of a specific color channel
6. During printing, ensure the print film does not rub against or contact the printhead to avoid damage or misalignment.
7. Keep the encoder strip clean—dust can interfere with print accuracy. Wipe it gently with a lint-free cloth every 1–2 weeks.
8. Lubricate the guide rails every 2–3 weeks using appropriate sewing machine oil.
9. Clean the wiper blade regularly with a lint-free cloth to maintain optimal capping and wiping performance.
10. Clean the ink on the paper presser promptly to prevent nozzle scratches caused by ink accumulation
11. Periodically clean accumulated ink from the bottom of the carriage (carriage base plate).
12. Regularly clean the ink accumulation around the capping station to ensure it remains clean.
13. If the printer will remain unused for an extended period: Place distilled water or a dedicated printhead cleaning solution into the capping station to soak the printhead. Clamp or pinch off the ink tubes and pump lines to prevent evaporation or back
14. When not in use, wrap the printing film with plastic wrap to prevent moisture damage.
15. When not in use, seal the hot-melt powder tightly in a bag to prevent moisture absorption